



news23

 **contardi**

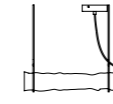
**indoor**

- B**
  - 8 BAGGY
  - 22 BIANCA
- F**
  - 32 FLY
- K**
  - 48 KIKI
- S**
  - 64 STICK

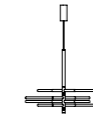
**outdoor**

- C**
  - 78 CLARA
- F**
  - 88 FLY OUTDOOR

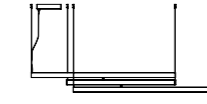
Suspension lamps



Baggy  
8



Bianca  
22



Fly  
32



Kiki  
48

Wall lights



Bianca  
22



Fly  
32



Kiki  
48

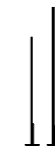


Stick  
64

Floor lamps



Baggy  
8



Fly  
32



Stick  
64

Table lamps

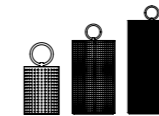


Baggy  
8



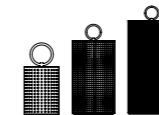
Kiki  
48

Battery lamps

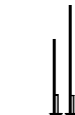


Clara  
78

Outdoor lamps



Clara  
78



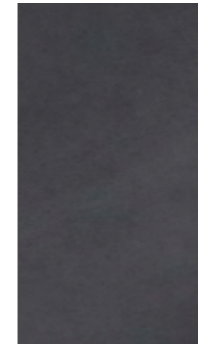
Fly outdoor  
88

INDOOR  
COLLECTION

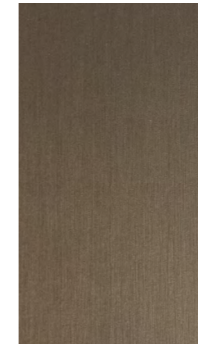
# MATERIALS AND COLORS

*INDOOR COLLECTION*

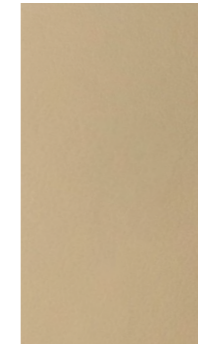
## Frame



Anthracite



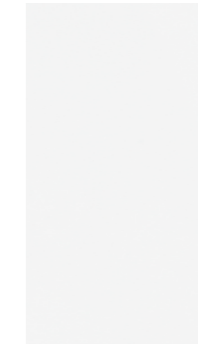
Brushed  
bronze-nickel



Gold lacquered



Satin golden  
nickel



Matt white  
lacquered



Satin copper

## Diffuser



Opal white glass



Dual satin  
polycarbonate



Striped plexiglass

## Accessories



White/grey color  
fabric rope



Orange color  
fabric cable



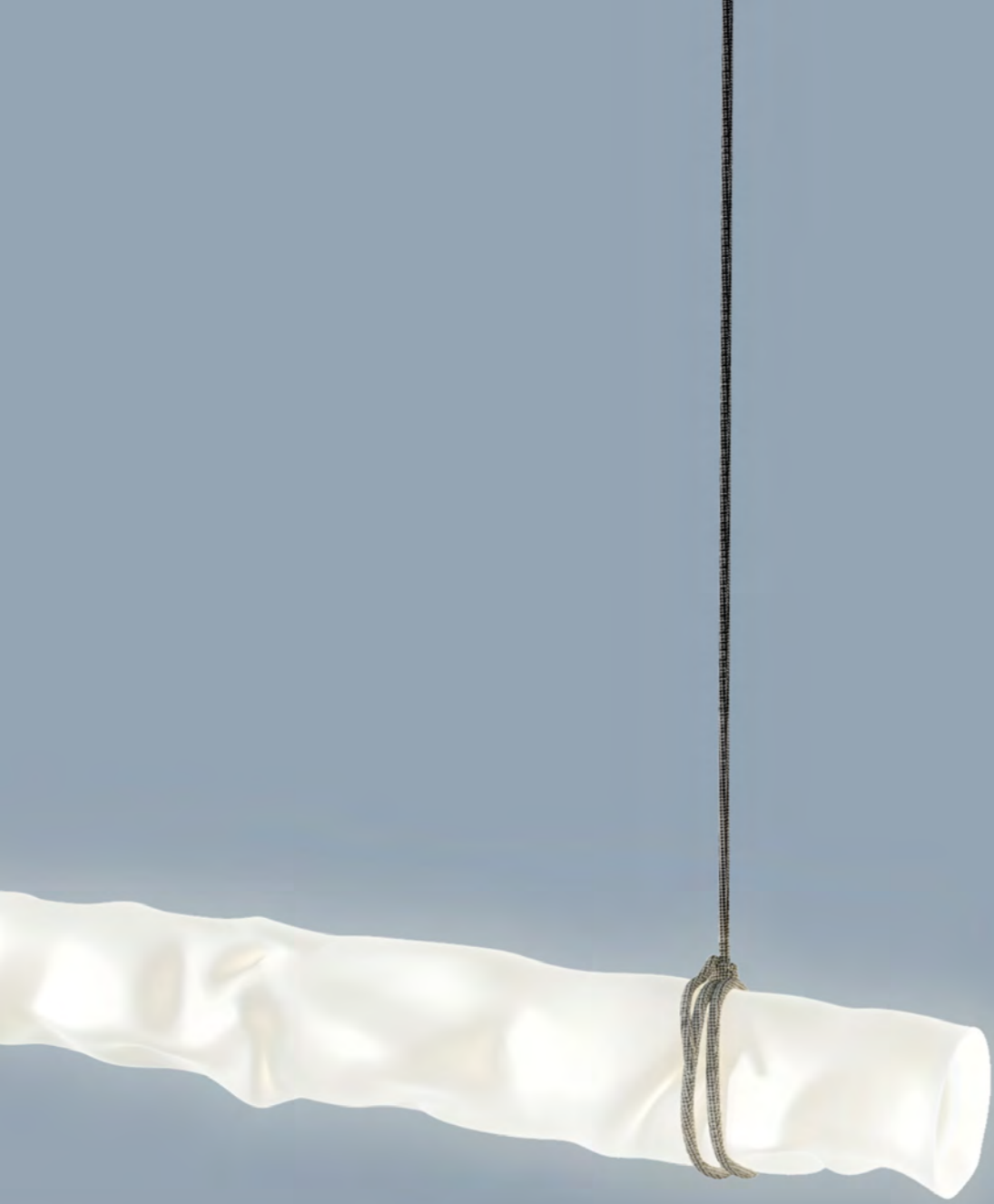
Sand color  
fabric cable



Black color  
fabric cable

# BAGGY

PAOLA NAVONE - OTTO STUDIO





“**Baggy** is the result of an irreplicable alchemy between our way of designing and Contardi. In a very special and pertinent way, Contardi has fostered the aptitude for imperfection in our design approach, accepting an interpretation of the company’s rigorous essence, in a project of lamps of ephemeral balance and an air of irony.”

**Paola Navone - Otto Studio**



“Horizontal” suspension version



“Vertical” and “Horizontal” suspension versions

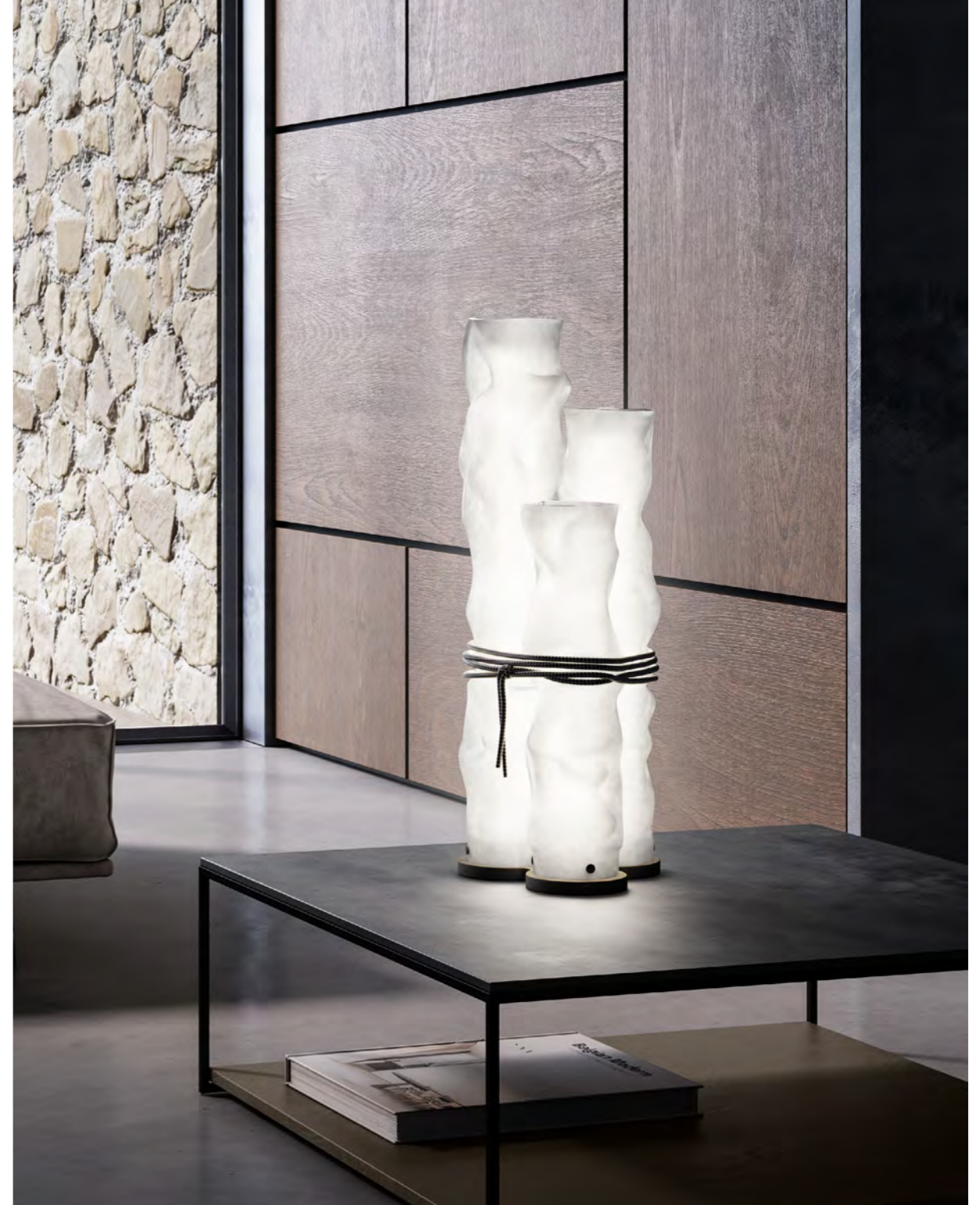




“Vertical” and “Horizontal” suspension versions



"Trio", "Small" and "Medium" table lamp versions



"Trio" table lamp version

Baggy is a collection of lamps with an informal and playful mood. Each Baggy lamp is composed of individual modules of different sizes that allow total freedom of composition.



"Trio" floor lamp version

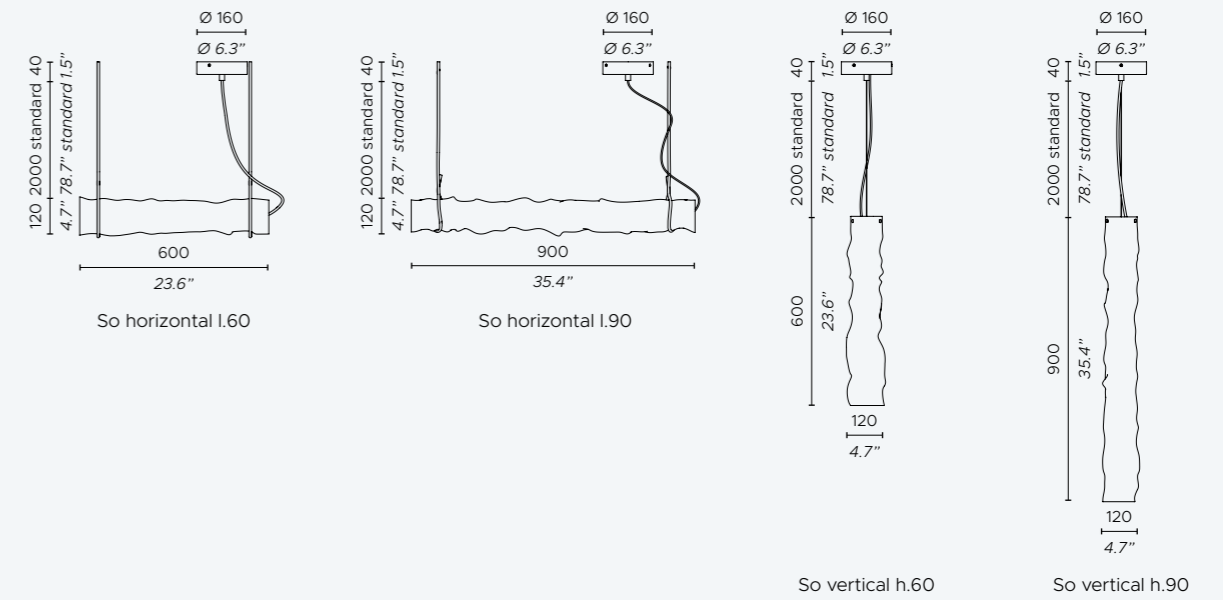


"Trio" floor lamp version

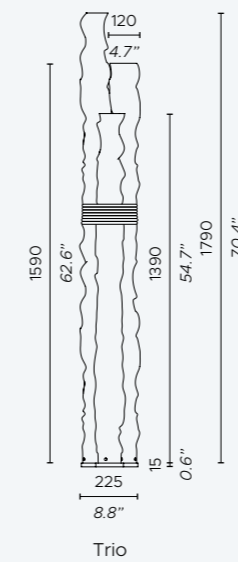
The dual satin polycarbonate diffuser has the irregular appearance of a crumpled paper tube. The soft textile cord, a detail in line with the brand's archi-decorative stylistic code, supports the lamp in the suspended version and becomes a joining element for the table and floor versions.



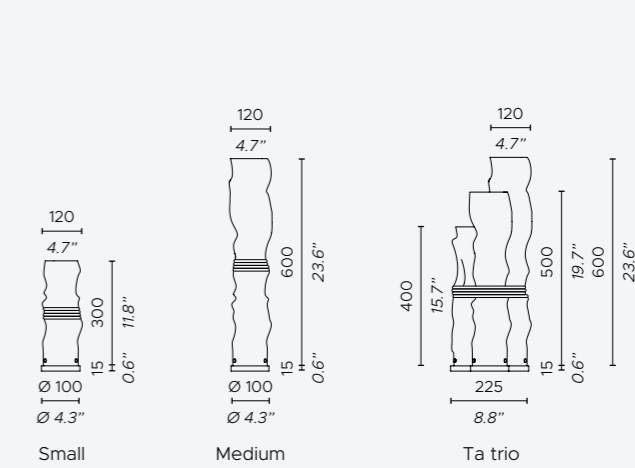
**Suspensions**





**Floor lamp**




**Table lamps**




**Frame**

-  Matt white laquered canopy (horizontal and vertical suspensions)
-  Grey lacquered base (table and floor versions)

**Diffuser**

-  Dual satin polycarbonate

**Accessory**

-  White/grey color fabric rope

**Light source**

**110V:**  
So - FI - Ta Custom Strip LED 15W/m

**So**  
Phase cut/Triac dimming - 1-10V dimming system available on demand  
**FI**  
Dimmable with foot control  
**Ta**  
Dimmable with switch on cable

# BIANCA

DAINELLI STUDIO





“The collaboration with Contardi immediately took on an unexpected rhythm. Our creativity, together with their experience in finding the best technical solution to achieve a desired lighting effect, has allowed us to generate a unique, functional product with a captivating image: **Bianca**. An encounter in the world of lighting that has been very precious for us.”

**Dainelli Studio**





Wall light

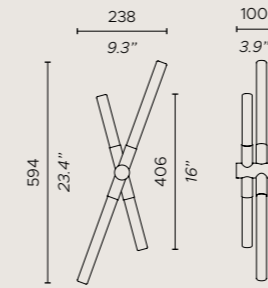
A product whose design is inspired by the structure of the snowflake. Bianca is a lamp composed of irregular modules, arranged in a precise sequence so as to guarantee its stability in both the wall and pendant versions.



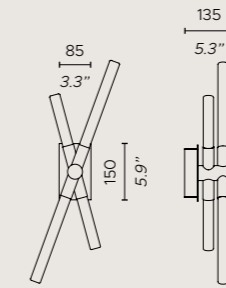




**Wall lights**

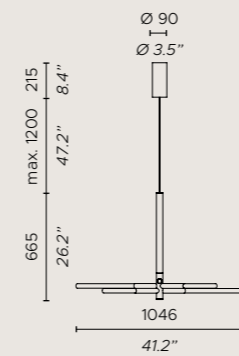


Without base - remote driver  
\*Supplied with plate to cover junction box  
ADA max 4,3"

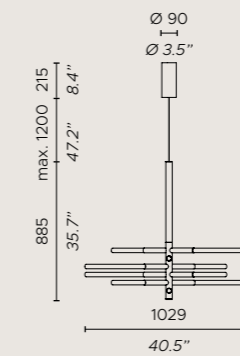


With base - driver on board  
\*Supplied with plate to cover junction box

**Suspensions**



So  
\*Supplied with plate to cover junction box



So double  
\*Supplied with plate to cover junction box

**Frame**

- Anthracite
- Gold lacquered

**Diffuser**

- Opal white glass

**Light source**

**110V:**

**Ap** 2 x 5W LED + 2 x 8W LED  
Light source included

**So** 2 x 5W LED + 2 x 8W LED + 2 x 10W LED  
Light source included

**So double** 4 x 5W LED + 4 x 8W LED + 4 x 10W LED  
Light source included

**Ap - So - So double**

Phase cut/Triac dimming - 1-10V dimming system available on demand

\*The junction box covers are supplied in white lacquered finish.  
Customers can paint over the metal plate using any color.



FLY

MASSIMILIANO RAGGI





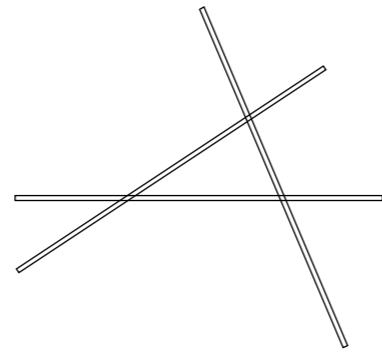
“I am linked to Contardi by a professional relationship, of fondness and friendship, which has lasted for over 15 years. I have grown up together with the brand, watching its growth and contributing to bring out its characteristics, its archi-decorative aesthetic code, gradually bringing it into the universe of lighting design, where **Fly** represents my contribution for the Collection.”

**Massimiliano Raggi**

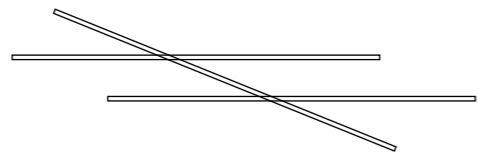




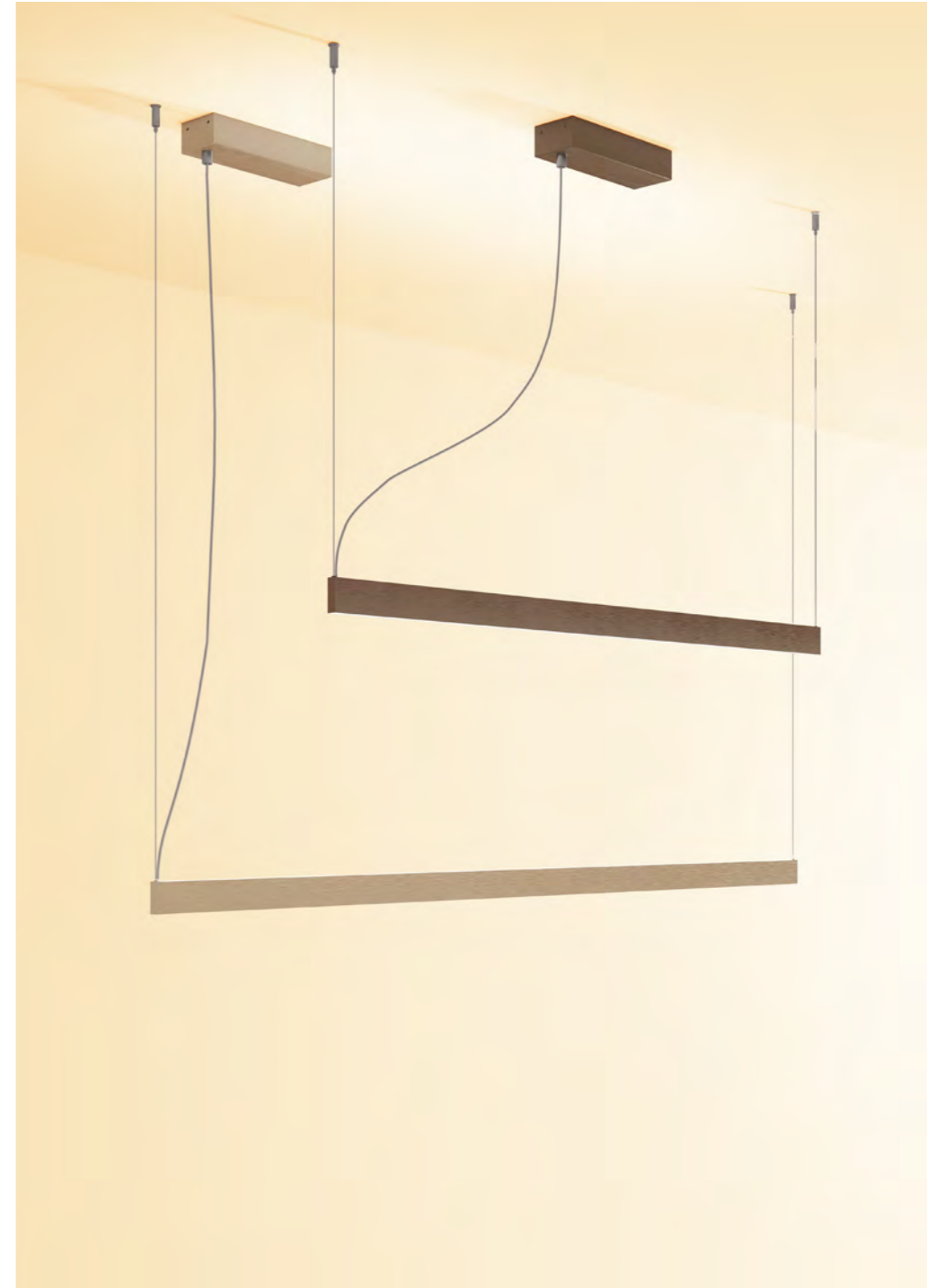
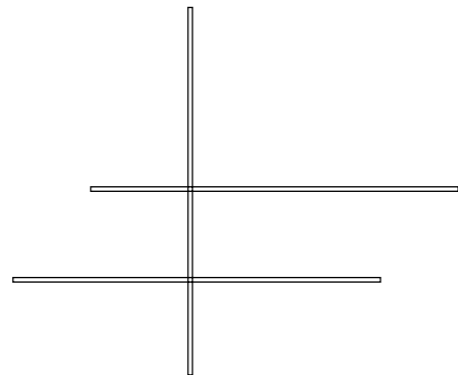
A.



B.



C.



"Linear" suspension versions



"FI" and "Long" floor lamp versions

Fly was born from the desire to design a product with a strong expressive force and at the same time light, like a pencil that runs longitudinally along the surface of a white sheet. A graphic sign whose proportions affirm the identity of an orthogonal structure that becomes essential luminous sculpture.

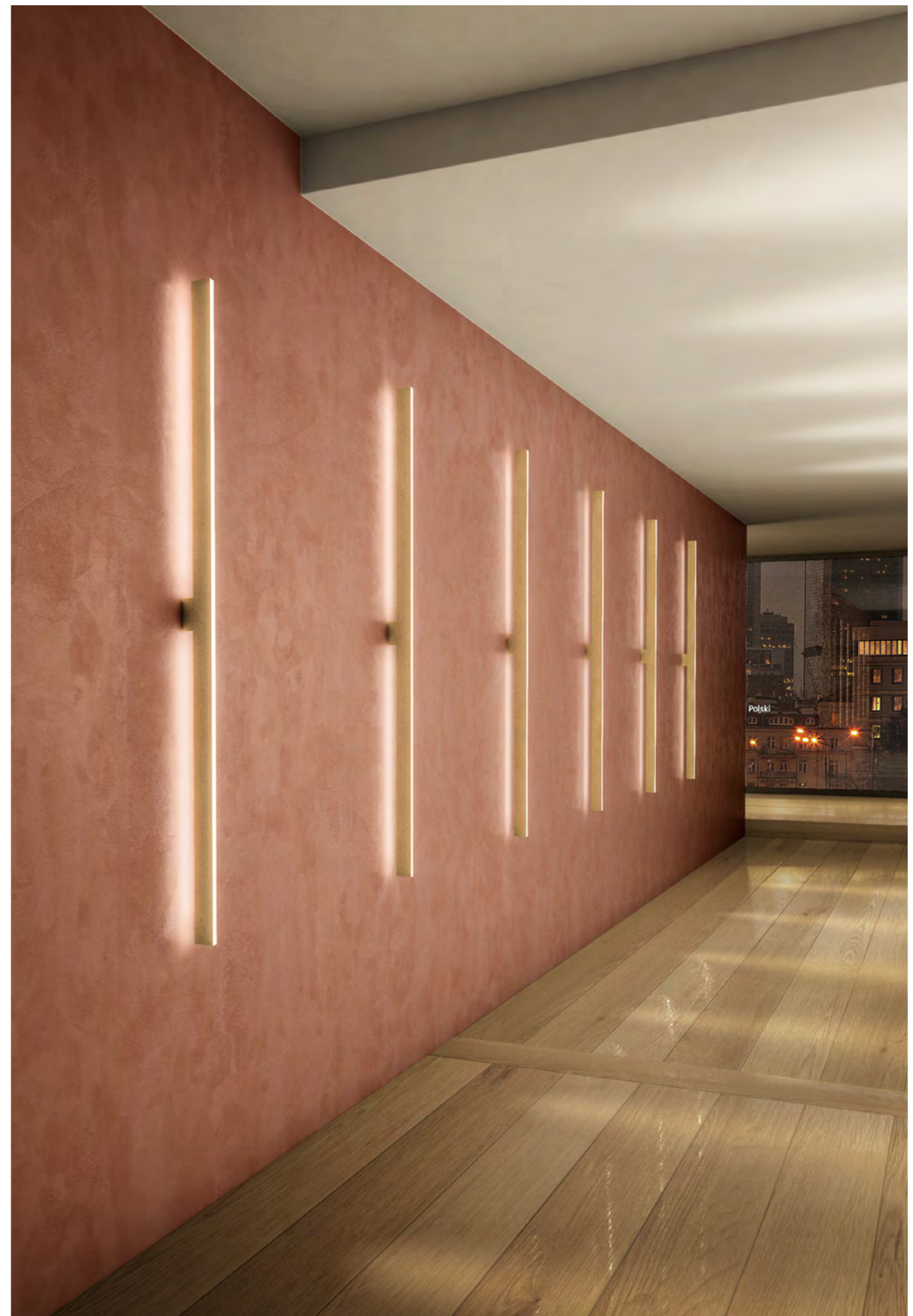


"Long" floor lamp version



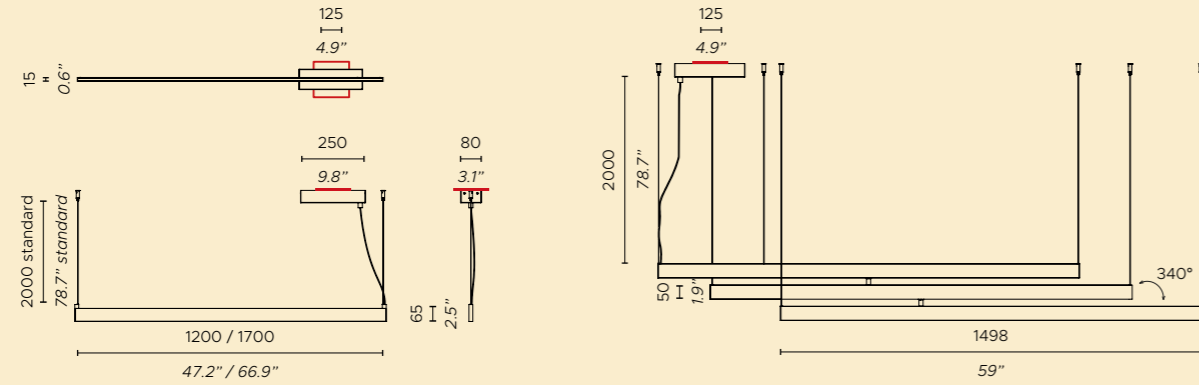
"Torch" floor lamp version - Vertical back and upper indirect light

Through a process of subtraction the luminous body, when turned on, disappears, revealing the mere presence of light. The double-sided profile, in its simplicity, allows to orient the light and emphasize it depending on the cut from which it emanates, distributing it in a timely and sophisticated way.



"Remote" wall light version - remote driver

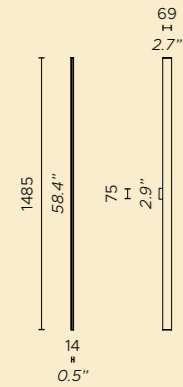
Suspensions



Linear I.120 / I.170  
\*Supplied with plate to cover junction box

Multiple  
\*Supplied with plate to cover junction box

Wall light






Remote  
ADA max 4.3"

"Remote" accessory





Vela

Frame

-  Anthracite
-  Satin golden nickel
-  Brushed bronze-nickel

Vela accessory

-  White cotton ("Remote version")
-  White Calacatta marble printed fabric ("Remote version")

Light source

- 110V:**  
Linear I.120 Upper 1 x 17W Strip LED;  
Down 1 x 23W Strip LED; 2700 K; CRI: >90
- Linear I.170 Upper 1 x 24W Strip LED;  
Down 1 x 33W Strip LED; 2700 K; CRI: >90
- Multiple Upper 1 x 42W Strip LED;  
Down 1 x 90W Strip LED; 2700 K; CRI: >90
- Remote Front 1 x 21W Strip LED;  
Back 2 x 14W Strip LED; 2700 K; CRI: >90

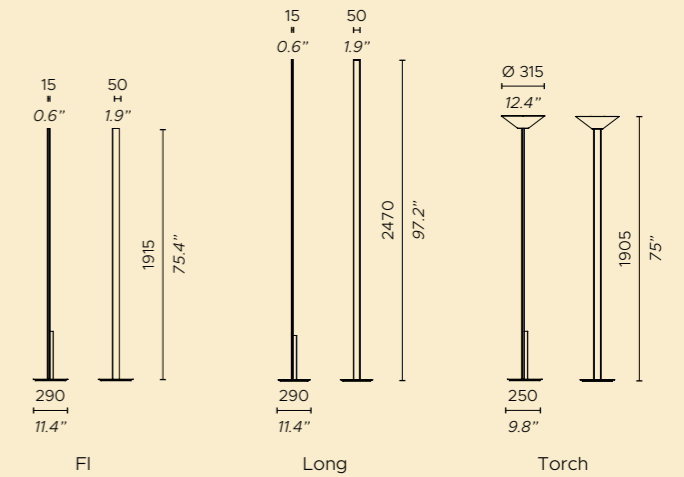
**Linear - Multiple - Remote**  
Phase cut/Triac dimming - 1-10V dimming system available on demand

\*The junction box covers are supplied in white lacquered finish.  
Customers can paint over the metal plate using any color.




Floor lamps



Double touch switch floor lamps



Frame

-  Anthracite
-  Satin golden nickel
-  Brushed bronze-nickel

Light source

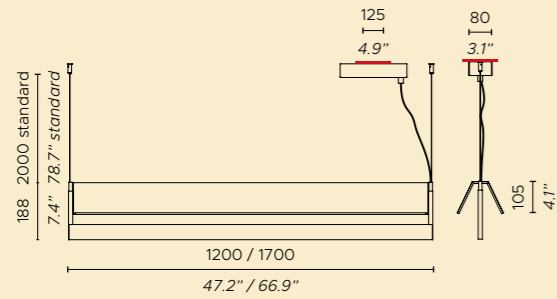
- 110V:**  
FI Front 1 x 26.5W Strip LED;  
Back 1 x 38W Strip LED; 2700 K; CRI: >90
- Long Front 1 x 34.5W Strip LED;  
Back 1 x 49W Strip LED; 2700 K; CRI: >90
- Torch Upper 1 x 34.5W Custom LED;  
Back 1 x 49W Strip LED; 2700 K; CRI: >90

**FI - Long**  
Dimmable front and back, double touch switch on board

**Torch**  
Dimmable vertical back and upper, double touch switch on board

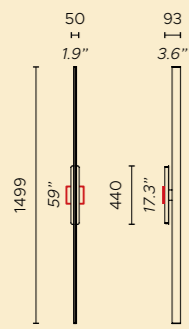


**Suspension**



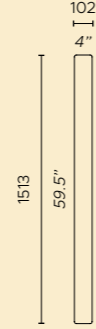
So I.120 / I.170  
\*Supplied with plate  
to cover junction box

**Wall light**






Ap  
\*Supplied with plate  
to cover junction box  
ADA max 4.3"

**Ap accessory**





Vela

**Frame**

-  Anthracite
-  Satin golden nickel
-  Brushed bronze-nickel

**Vela accessory**

-  White cotton
-  White Calacatta marble printed fabric

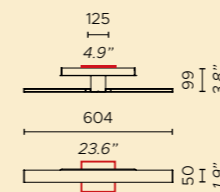
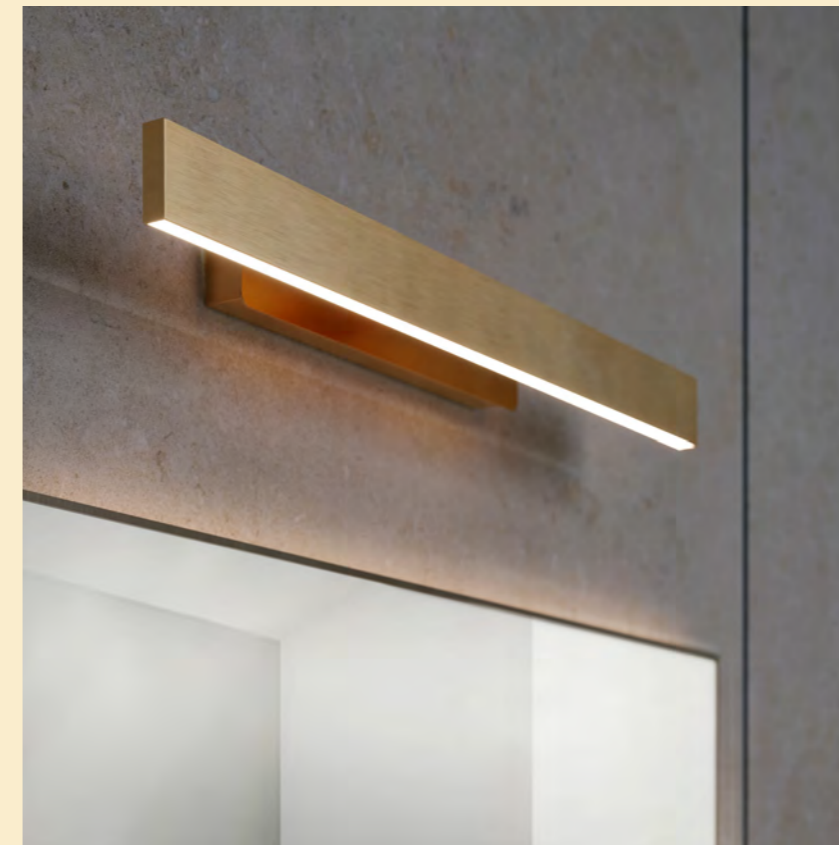
**Light source**

**110V:**  
So I.120 Upper 1 x 17W Strip LED;  
Down 1 x 23W Strip LED; 2700 K; CRI: >90  
So I.170 Upper 1 x 24W Strip LED;  
Down 1 x 33W Strip LED; 2700 K; CRI: >90  
Ap Front 1 x 21W Strip LED;  
Back 2 x 14W Strip LED; 2700 K; CRI: >90

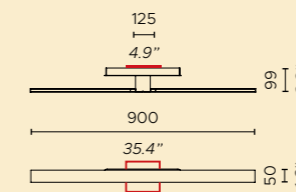
**So - Ap**  
Phase cut/Triac dimming - 1-10V dimming system available on demand

\*The junction box covers are supplied in white lacquered finish.  
Customers can paint over the metal plate using any color.

**Wall lights**



Picture - IP44  
\*Supplied with plate  
to cover junction box



Picture large - IP44  
\*Supplied with plate  
to cover junction box

**Frame**

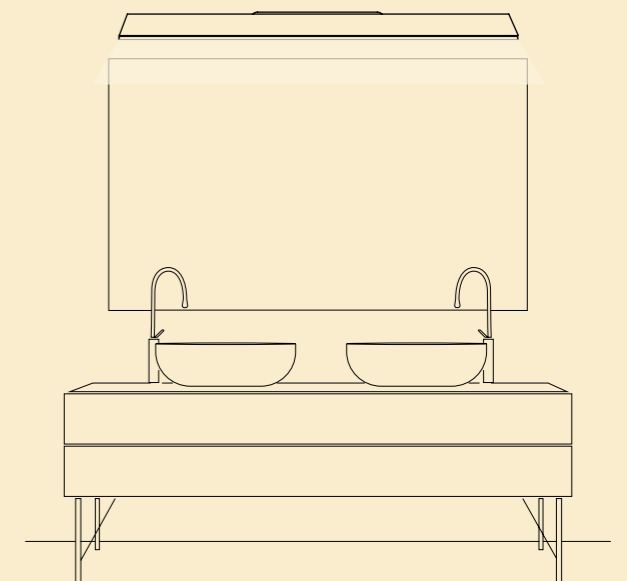
-  Anthracite
-  Satin golden nickel
-  Brushed bronze-nickel
-  Satin copper

**Light source**

**110V:**  
Picture 1 x 11.5W Strip LED; 2700 K; CRI: >90; IP44  
Picture large 1 x 17.5W Strip LED; 2700 K; CRI: >90; IP44

**Picture - Picture large**  
Phase cut/Triac dimming - 1-10V dimming system available on demand

\*The junction box covers are supplied in white lacquered finish.  
Customers can paint over the metal plate using any color.



Application example Fly picture large

A minimalist lighting fixture is shown against a light beige background. It consists of four circular, white, disc-shaped shades of varying sizes, connected by a thick, textured red cord. The shades are arranged in a diamond pattern, with one at the top, one at the bottom, one on the left, and one on the right. The lighting is soft and even, highlighting the texture of the cord and the smooth surface of the shades.

KIKI  
CONTARDI STUDIO



“With **Kiki** we have expressed the desire to be in the collection ourselves, side by side with great designers, with a product developed in-house that would respond to the requirements of the market while expressing our concept of lamps. Functional decorative objects, tools at the service of the most creative architects and interior designers.”



Suspensions

Kiki is a modular product available in suspension, wall and table versions. The tone-on-tone fabric cable, or to its contrast with the structure, this product allows creative compositions on walls. With the pendant version it is possible to create scenographic clusters.



Wall light



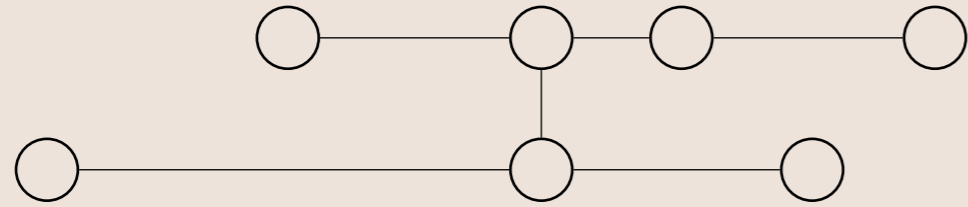
Wall lights



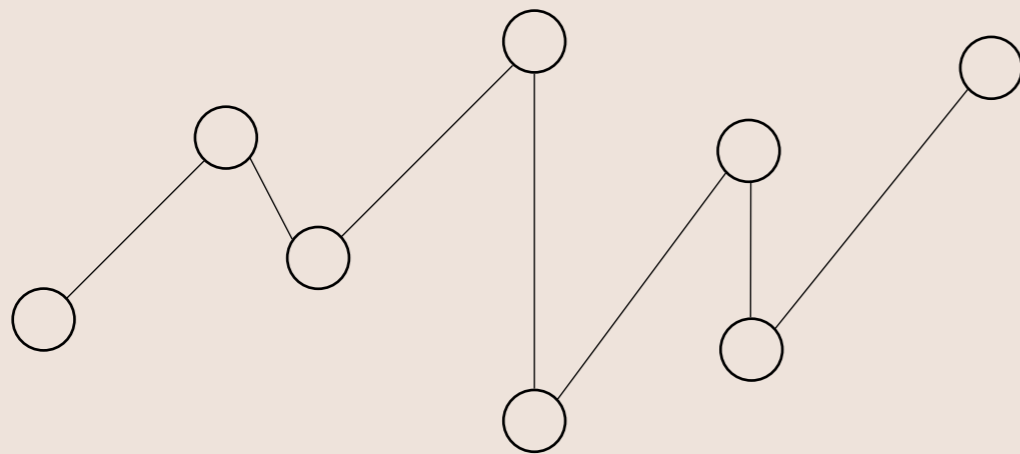
"Kiki connect" modular system



A. Linear composition

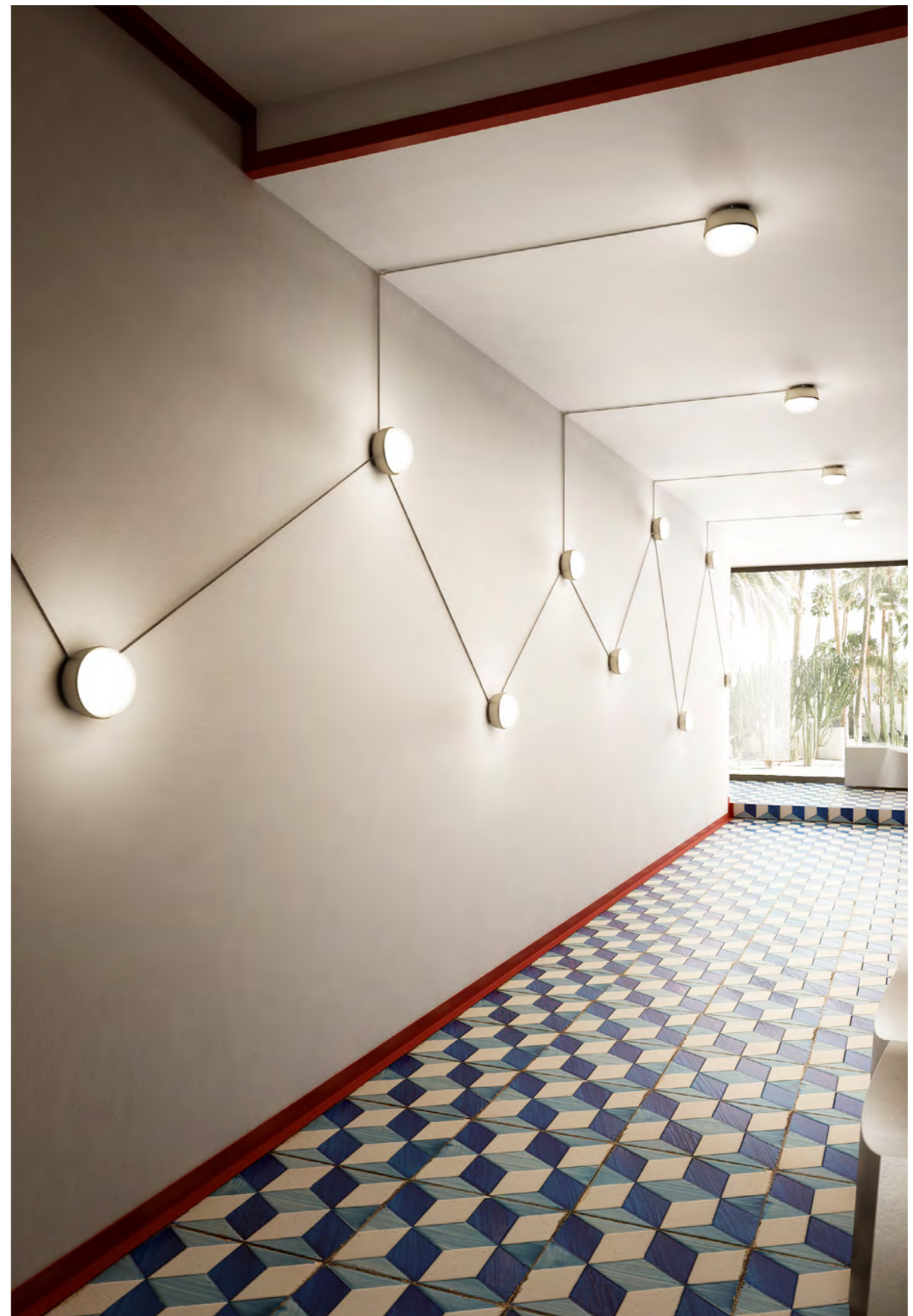


B. Multiple linear composition



C. Irregular composition

Driver on board compatible with phase cut/Triac - Possibility of creating infinite compositions from a single electrical output.  
Cable outlet at 45°.  
Possibility of connection to the socket with plug and switch control.



"Kiki connect" modular system



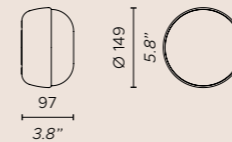
"Kiki connect" modular system with plug



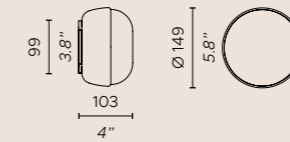


Table lamp

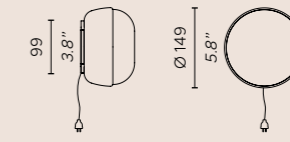
Wall lights



Ap  
IP44 - ADA max 4,3"

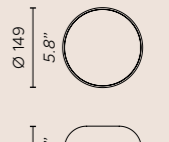


Ap connect  
IP44 - ADA max 4,3"



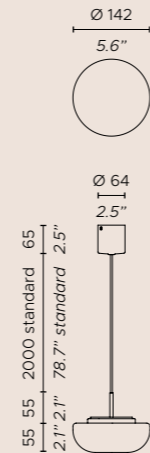
Ap connect with plug  
IP44 - ADA max 4,3"

Table lamp

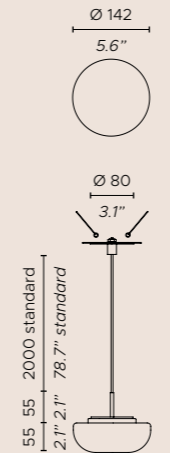


Ta

Suspensions

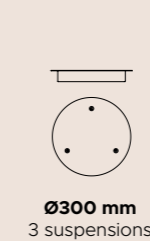


With canopy  
\*Supplied with plate to cover junction box

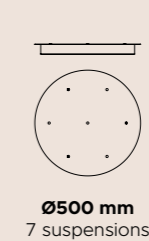


Without canopy

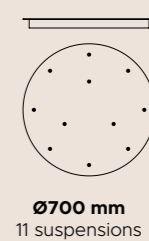
Round clusters



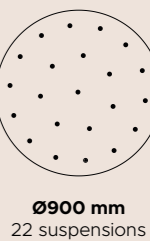
Ø300 mm  
3 suspensions



Ø500 mm  
7 suspensions

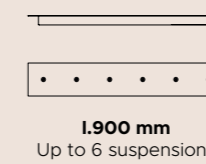


Ø700 mm  
11 suspensions

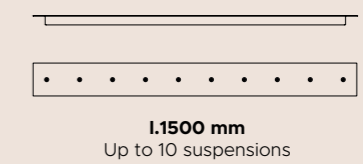


Ø900 mm  
22 suspensions

Linear clusters

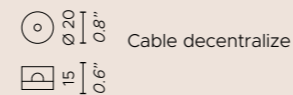


1.900 mm  
Up to 6 suspensions



1.1500 mm  
Up to 10 suspensions

So - Ap connect accessory



Frame

- Anthracite
- Satin golden nickel
- Brushed bronze-nickel
- Matt white lacquered (Ap - Ap connect)

Diffuser

- Satin opal glass

Ap connect accessories

- Orange color fabric cable
- Sand color fabric cable
- Black color fabric cable

Light source

**110V:**  
Ap - So - Ta 1 x 5W Custom LED; 550 Lm; 2700 K;  
CRI: >90

Ap - So  
Phase cut/Triac dimming - 1-10V dimming system available on demand  
Ta  
Dimmable, push switch on the base

\*The junction box covers are supplied in white lacquered finish.  
Customers can paint over the metal plate using any color.



# STICK

STUDIOPEPE





“The purity we wanted to achieve with **Stick** has been reached thanks to collaboration with the light technicians of Contardi. To design every constructive detail, down to the smallest, together with their theme has permitted us to obtain a prism of extreme refinement, simple and essential on the outside, but containing complex technology.”

**Studiopepe**



Floor lamps

In Stick the light emanates, skillfully modulated, through a diffuser with a ribbed glass effect, contained within a metal extrusion in satin copper and gold nickel finishes.

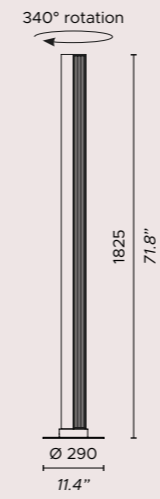


Floor lamp

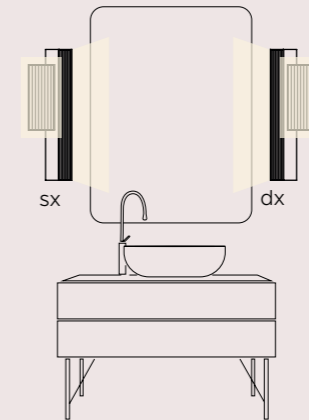
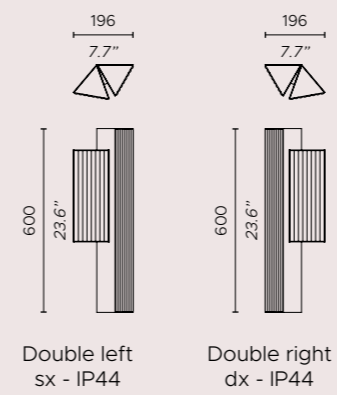


Wall lights

**Floor lamp**





**Wall lights**




Application example  
ap double right and left

**Frame**

-  Satin golden nickel
-  Satin copper

**Diffuser**

-  Striped plexiglass

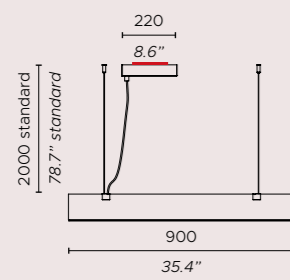
**110V:**

**Ap left and right** 1 x 13.5W Custom LED + 1 x 27W Custom LED; 3750 Lm; 2700 K; CRI: >90; IP44  
**FI** 5 x 13.5W Custom LED; 7500 Lm; 2700 K; CRI: >90

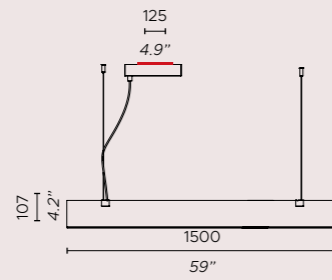
**Ap double left and right**

Phase cut/Triac dimming - 1-10V dimming system available on demand  
**FI**  
 Foot dimmable

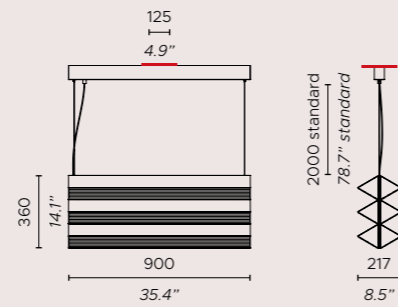
## Suspensions



Small I.90  
\*Supplied with plate  
to cover junction box

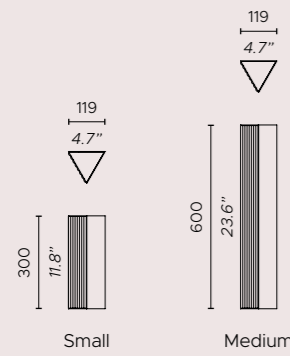


Large I.150  
\*Supplied with plate  
to cover junction box

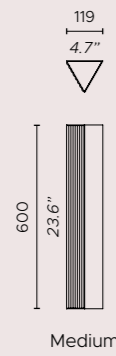


Trio  
\*Supplied with plate  
to cover junction box

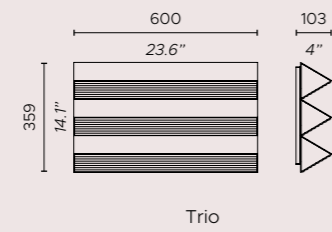
## Wall lights



Small



Medium



Trio

## Light source

## 110V:

So small I.90 1 x 40W Custom LED; 3750 Lm;  
2700 K; CRI: >90

So large I.150 1 x 65W Custom LED; 6250 Lm;  
2700 K; CRI: >90

So trio 6 x 40W Custom LED; 22500 Lm;  
2700 K; CRI: >90

Ap small 1 x 13.5W Custom LED; 1250 Lm;  
2700 K; CRI: >90

Ap medium 1 x 27W Custom LED; 2500 Lm;  
2700 K; CRI: >90

Ap trio 3 x 27W Custom LED; 7500 Lm;  
2700 K; CRI: >90

Phase cut/Triac dimming - 1-10V dimming system available on demand

\*The junction box covers are supplied in white lacquered finish.  
Customers can paint over the metal plate using any color.





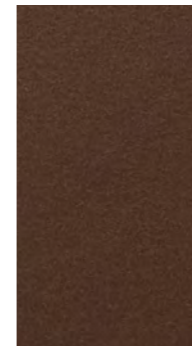
OUTDOOR  
COLLECTION  
IP65



# MATERIALS AND COLORS

## *OUTDOOR COLLECTION*

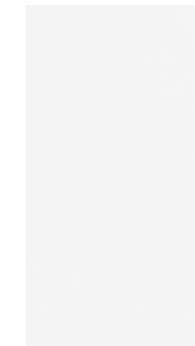
### Frame



Bronze lacquered



Black lacquered



Matt white  
lacquered

### Diffuser



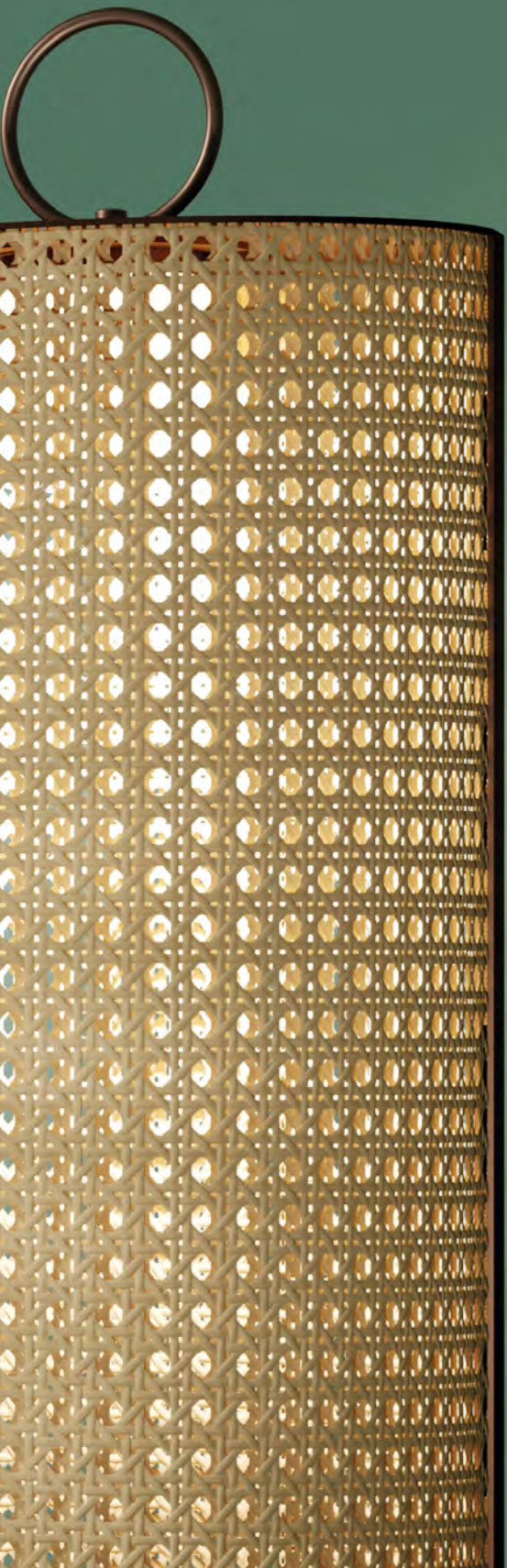
Vienna straw  
resin effect



# CLARA

CHIARA CABERLON

in collaboration with Marco Forbicioni





“The **Clara** collection of lamps has been created to respond to a request on the part of Contardi to formulate an outdoor collection IP65 for the contract market.

The result is a portable lantern with a nomadic spirit, which thanks to the company’s incredible expertise and approach to materials broadcasts magical, warm and evocative light.”

**Chiara Caberlon**  
in collaboration with  
**Marco Forbicioni**



"Small" battery-powered version

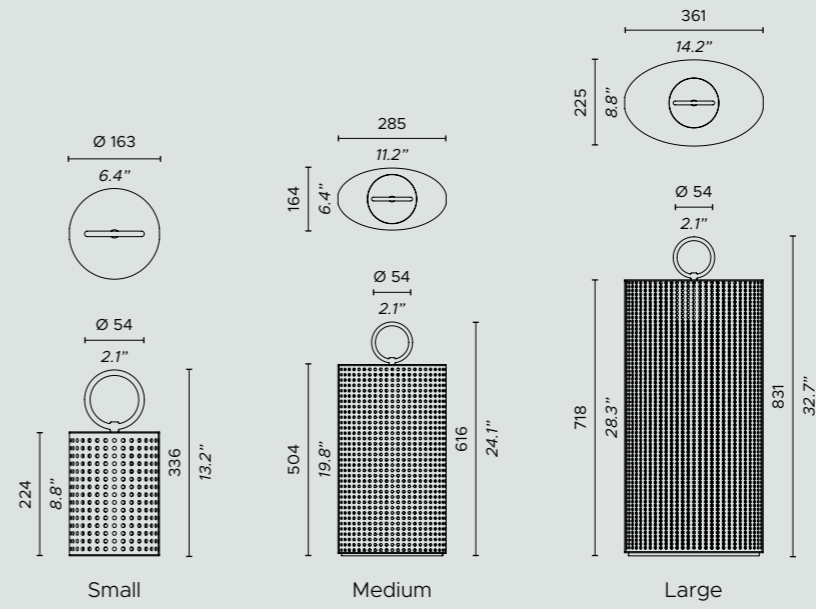
Clara comes from the concept of "bringing light". A light element easily transportable anywhere, thanks to the choice of the rechargeable battery power supply and the presence of a ring allocated at the top that serves as a hook to hang or move it.



Battery-powered lamps



Battery-powered lamps

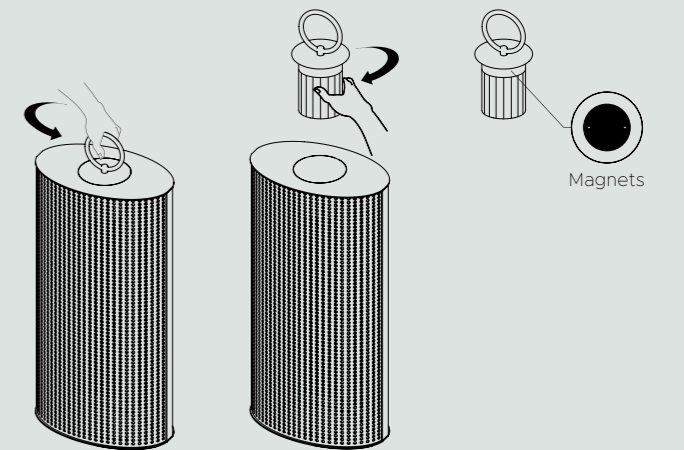


Removable, transportable, rechargeable light source


TRANSPORTABILITY




ON / OFF SWITCHING




Frame

 Matt white lacquered

 Bronze lacquered

Diffuser

 Vienna straw resin effect

Light source

Battery 1 x 4W LED module; 400 Lm; 2700 K; CRI: >90

IP65

FLY  
OUTDOOR  
MASSIMILIANO RAGGI



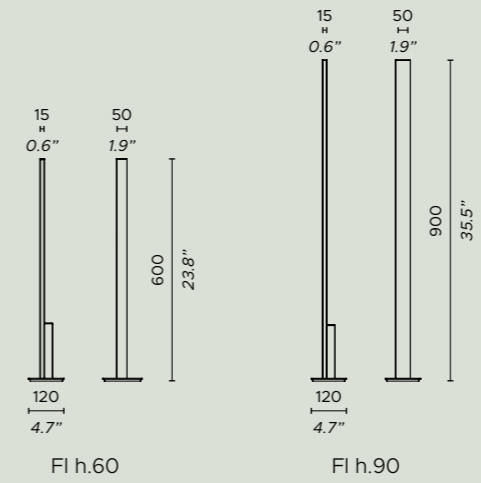


Outdoor floor lamps



Outdoor floor lamps

Floor lamps



Frame

- Black lacquered
- Bronze lacquered

Light source

FI h.60 1 x 8W Custom LED; 2700 K  
 FI h.90 1 x 12.5W Custom LED; 2700 K

IP65



## THANKS TO

**Graphic Project:**

Claudia Parisi

**Mise en page:**

Martina Castiglieri

**Photos:**

Marco Reggi

**Render:**

Arché Agency

Officine Mimesi

Dainelli Studio

**Print:**

Grafiche Antiga, Crocetta del Montello (TV)

©Contardi Lighting srl

07.2023

**CONTARDI USA Inc***USA Branch*151 Wooster St - Floor 2  
10012 New York - NY**CONTARDI LIGHTING SRL***Italy Headquarters*Via A. Manzoni, 134/140  
20811 Cesano Maderno (MB)**CONTARDI MILANO***Showroom*Corso Monforte, 20  
20122 Milan (MI)

**CONTARDI USA Inc**

*USA Branch*

151 Wooster St - Floor 2  
10012 New York - NY  
Phone: +1 718 715 0717  
Mail: office@contardi-usa.com

**contardi-usa.com**

---

**CONTARDI LIGHTING Srl**

*Italy Headquarters*

Via A. Manzoni, 134/140  
20811 Cesano Maderno (MB)  
Phone: +39 0362 301381  
Mail: sales@contardi-italia.it

**contardi-italia.com**

---

**CONTARDI MILANO**

*Showroom*

Corso Monforte, 20  
20122 Milano (MI)  
Phone: +39 02 82 76 5952  
Mail: milano@contardi-italia.it

**contardi-italia.com/showroom**

Follow **Contardi Lighting** on:

