

ASTRALBRIDGECASTELC  
RYROCKDUOEFFECTGIRA  
SOLEGLEAMMIKADONEV  
ANOBODYPATCHWORKP  
ROFILEQUADRORAINBOW  
RHYTHMSOUNDVECTOR

**TXXNTY**

BRAND

DESIGN

LIGHT OF ITALY

XXBD.20



ASTRALBRIDGECASTELC  
RYROCKDUJOEFFECTGIRA  
SOLEGLEAMMIKADONEV  
ANOBODYPATCHWORKP  
ROFILEQUADRORAINBOW  
RHYTHMSOUNDVECTOR

XXBD.20

ASTRALBRIDGECASTELC  
RYROCKDUOEFFECTGIRA  
SOLEGLEAMMIKADONEVA  
NOBODYPATCHWORKP  
ROFILEQUADRORAINBOW  
RHYTHMSOUNDVECTOR

Astral è lo spettacolo del cosmo rutilante con le sue costellazioni: le stelle, come fori nel cielo, lasciano filtrare la luce dell'infinito.

*Astral is the spectacle of the dazzling cosmos with its constellations: the stars, like holes in the sky, let the light of infinity filter through.*

**Studio in project**

DESIGN BY  
STUDIO IN PROJECT

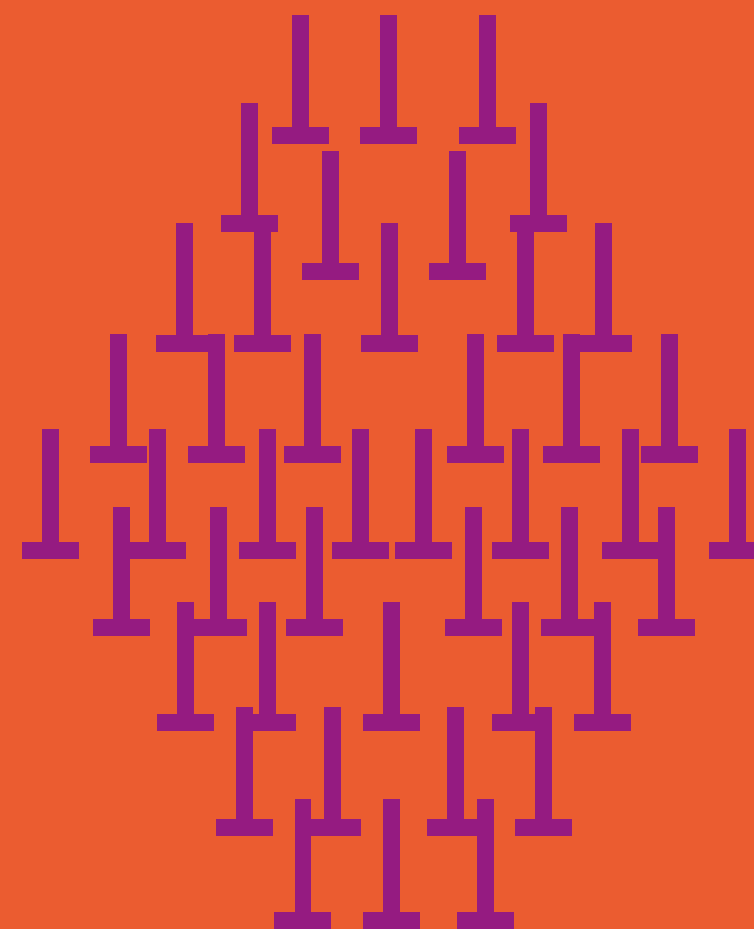

ASTRAL

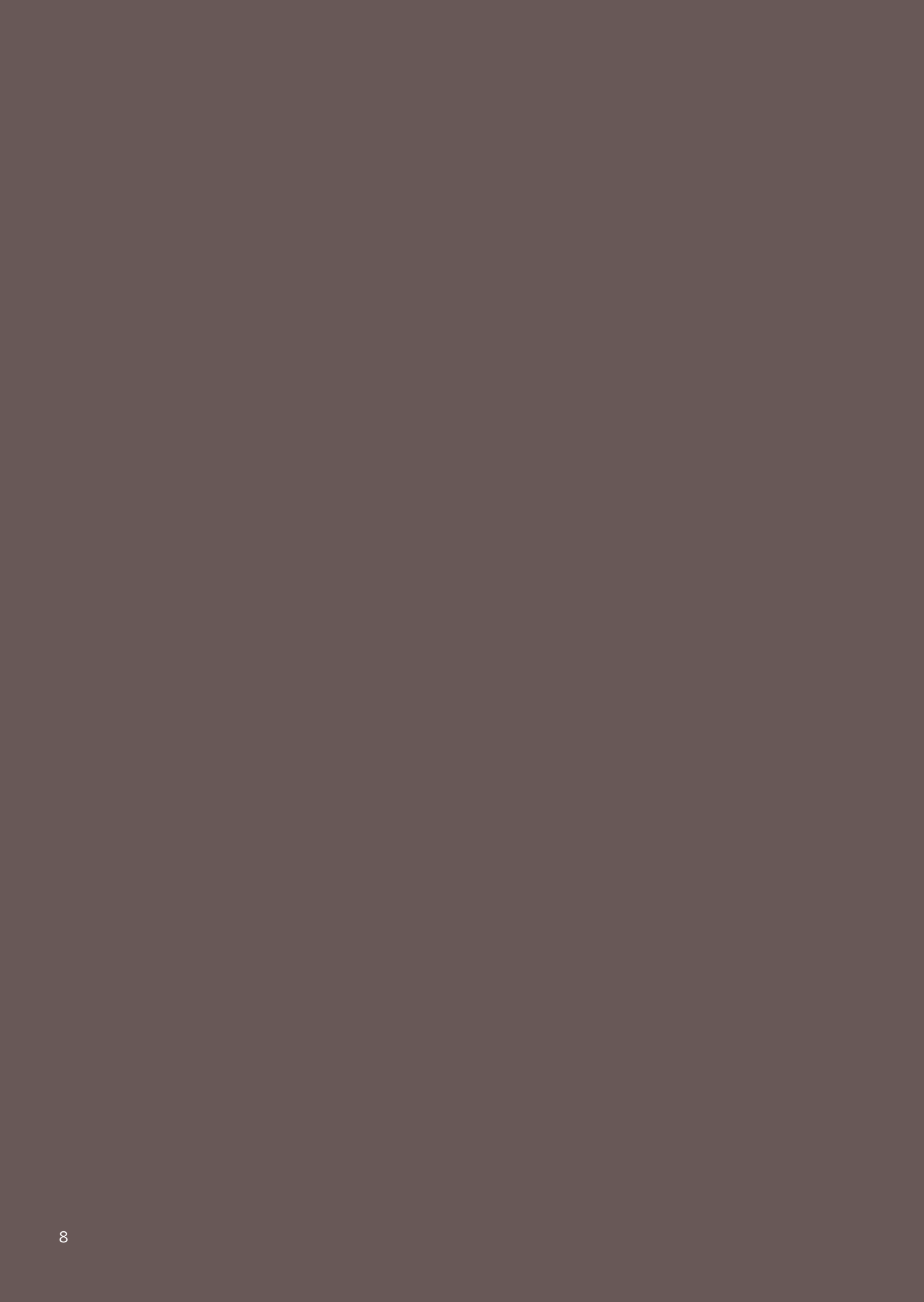









ASTRALBRIDGECASTELC  
RYROCKDUOEFFECTGIRA  
SOLEGLEAMMIKADONEVA  
NOBODYPATCHWORKP  
ROFILEQUADRORAINBOW  
RHYTHMSOUNDVECTOR

C'è un legame, un accordo tra l'uomo e la natura:  
il primo crea qualcosa di utile e la natura  
comincia a giocare con riflessi e sfumature  
donandogli armonia.

*There is a bond, an agreement between man and  
nature: the former creates something useful and  
nature begins to play with it, adding highlights  
and nuances, bringing it harmony.*

**Nunzia Acquaviva**

DESIGN BY  
NUNZIA ACQUAVIVA



**BRIDGE**



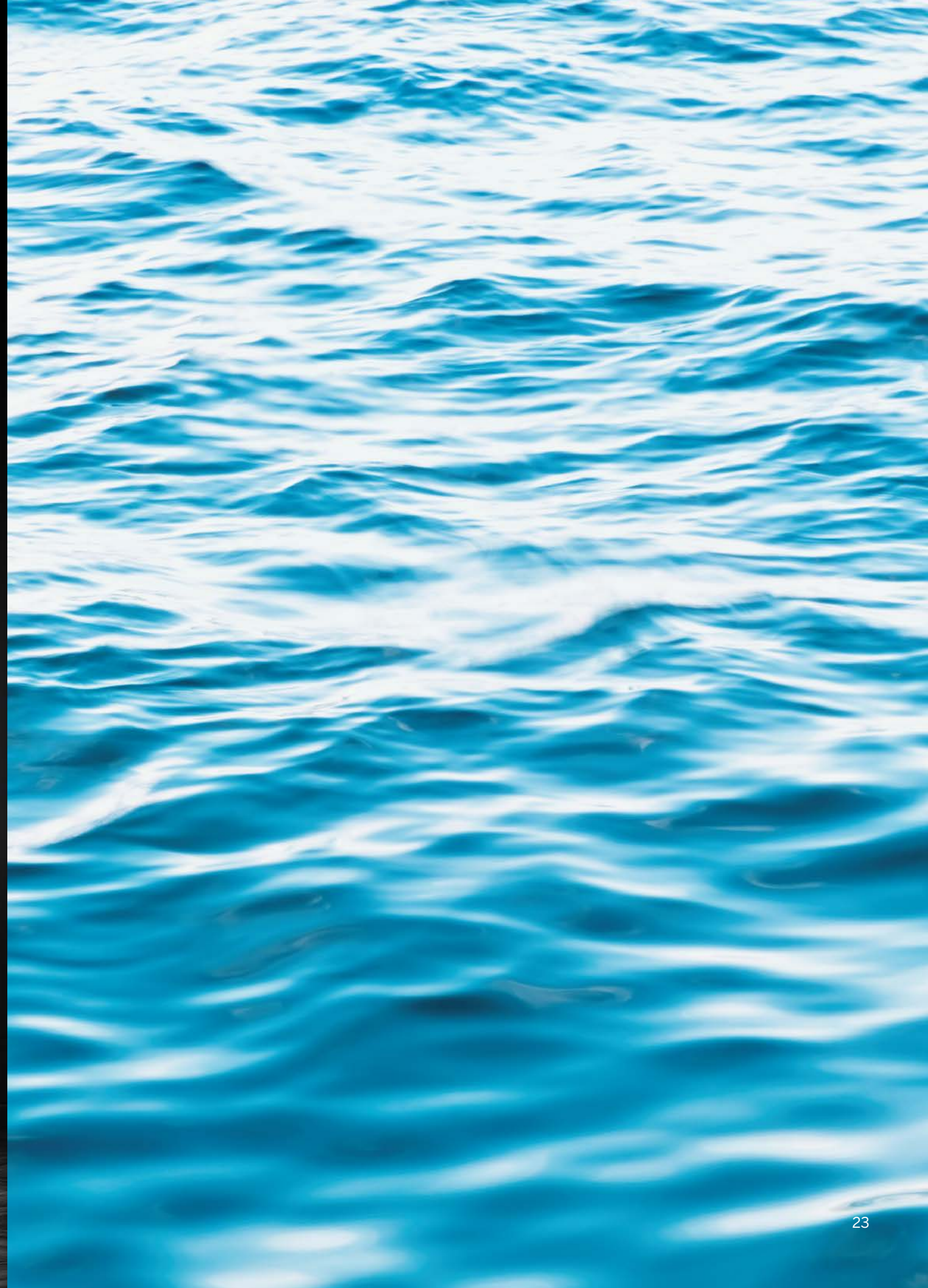

ASTRALBRIDGECASTELC  
RYROCKDUOEFFECTGIRA  
SOLEGLEAMMIKADONEVA  
NOBODYPATCHWORKP  
ROFILEQUADRORAINBOW  
RHYTHMSOUNDVECTOR

L'alchimia della luce svela le sfaccettature dell'Architettura e la trasmuta in Design. La collezione si ispira all'architettura di Castel del Monte interpretando in chiave contemporanea un pezzo unico e singolare della tradizione architettonica pugliese. La geometria ottagonale, caratteristica peculiare di ogni lampada, riflette e assorbe le variazioni di luce e colore in una stanza: ogni faccia è sempre diversa dall'altra, e ognuna di esse cristallizza i cromatismi cangianti degli ambienti che lo circondano.

*The alchemy of light reveals the facets of Architecture and transposes them into Design. The collection is inspired by the architecture of Castel del Monte, offering a contemporary interpretation of a unique and singular piece of Apulian architectural tradition. The octagonal geometry, which is a particular feature of each lamp, reflects and absorbs the fluctuations of light and colour in a room: every face is always different from the other, and each one crystallizes the iridescent colours of the rooms around it.*

**Vincenzo Bafunno**

DESIGN BY  
VINCENZO BAFUNNO

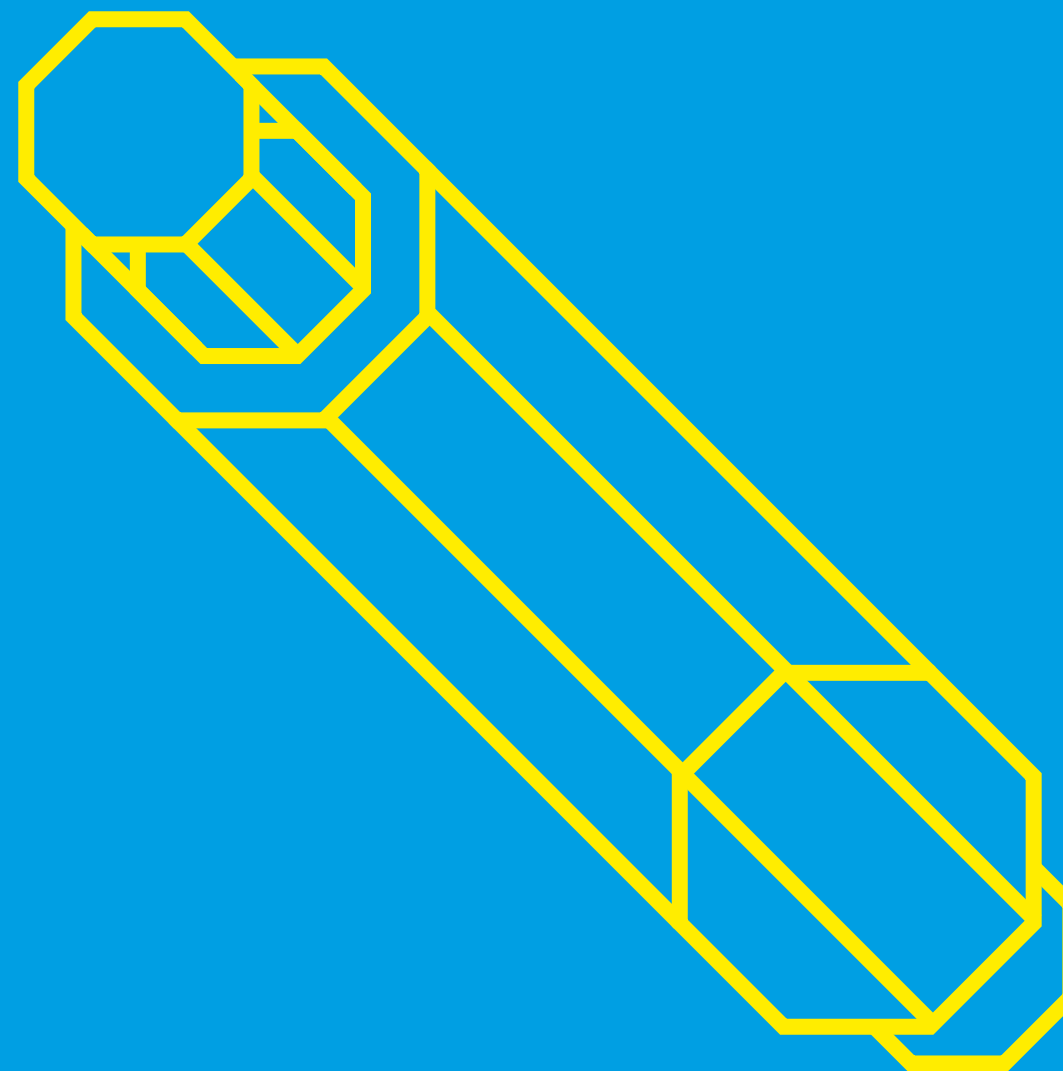

CASTEL





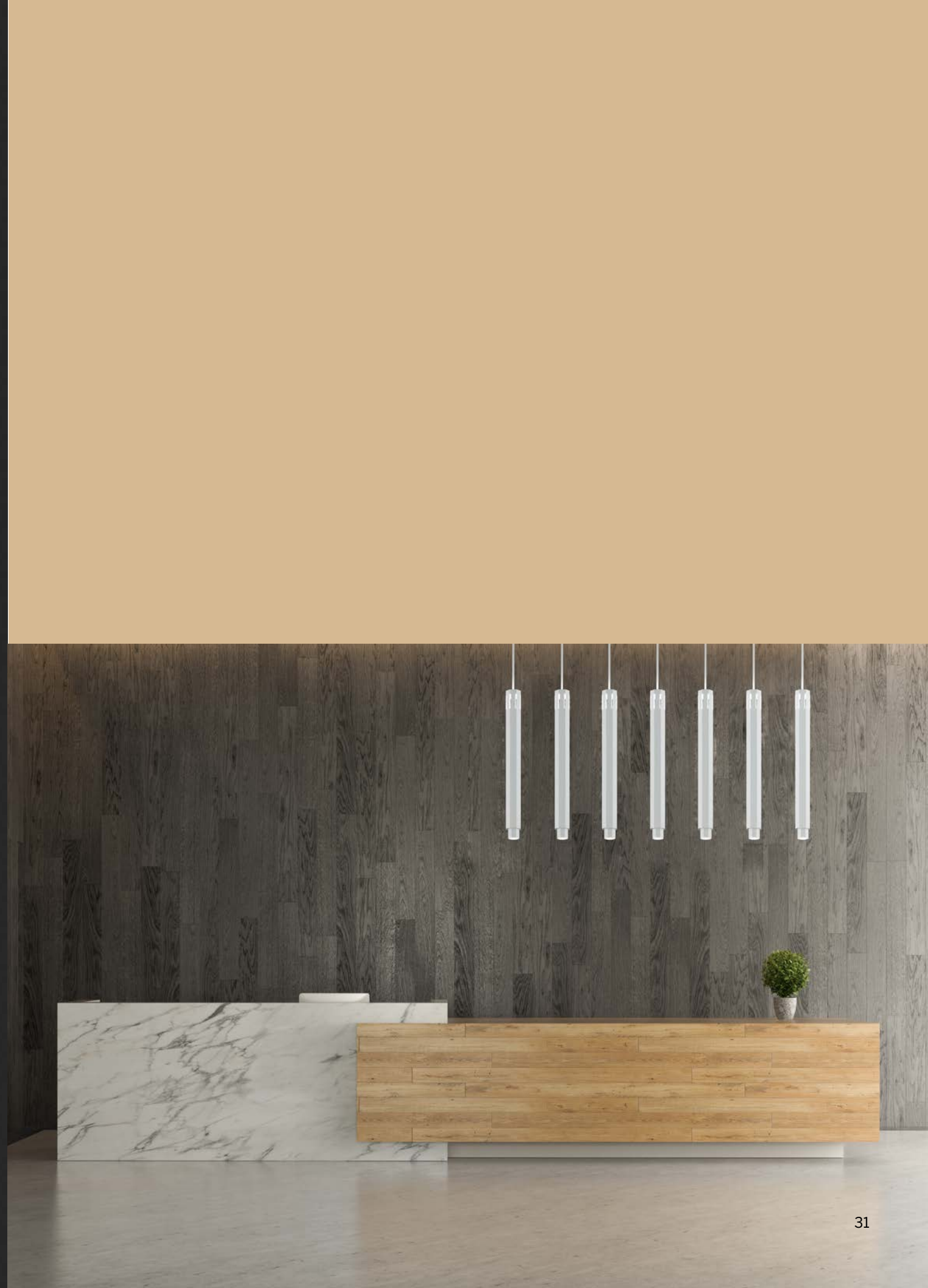

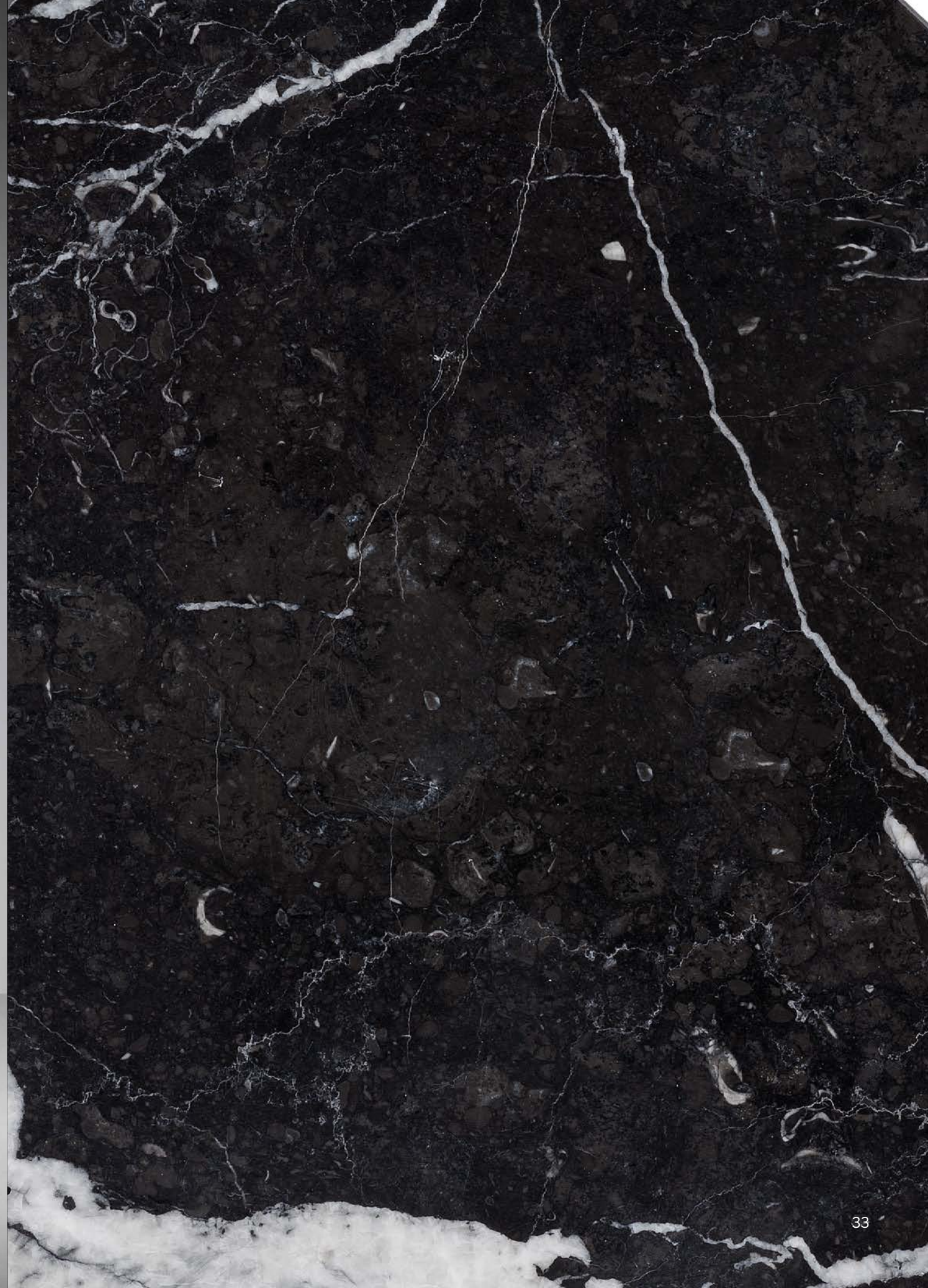

ASTRALBRIDGECASTELC  
RYROCKDUOEFFECTGIRA  
SOLEGLEAMMIKADONEVA  
NOBODYPATCHWORKP  
ROFILEQUADRORAINBOW  
RHYTHMSOUNDVECTOR

È affascinante l'universo con la sua energia.  
Misterioso, buio eppure pieno di luci.

*The universe and its energy are fascinating.  
Mysterious and dark, yet full of lights.*

**Michele Losito**

DESIGN BY  
MICHELE LOSITO

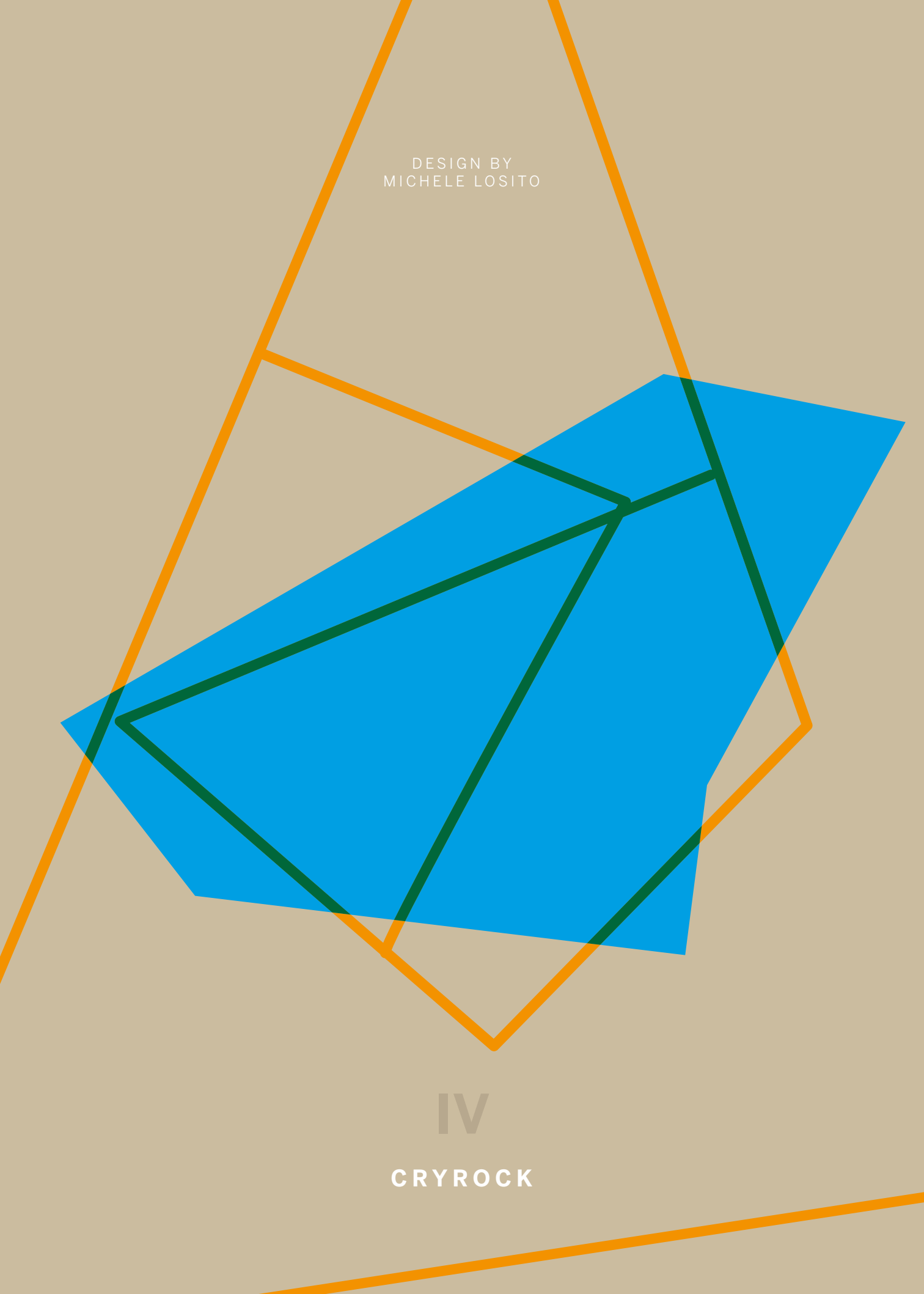

IV  
CRYROCK

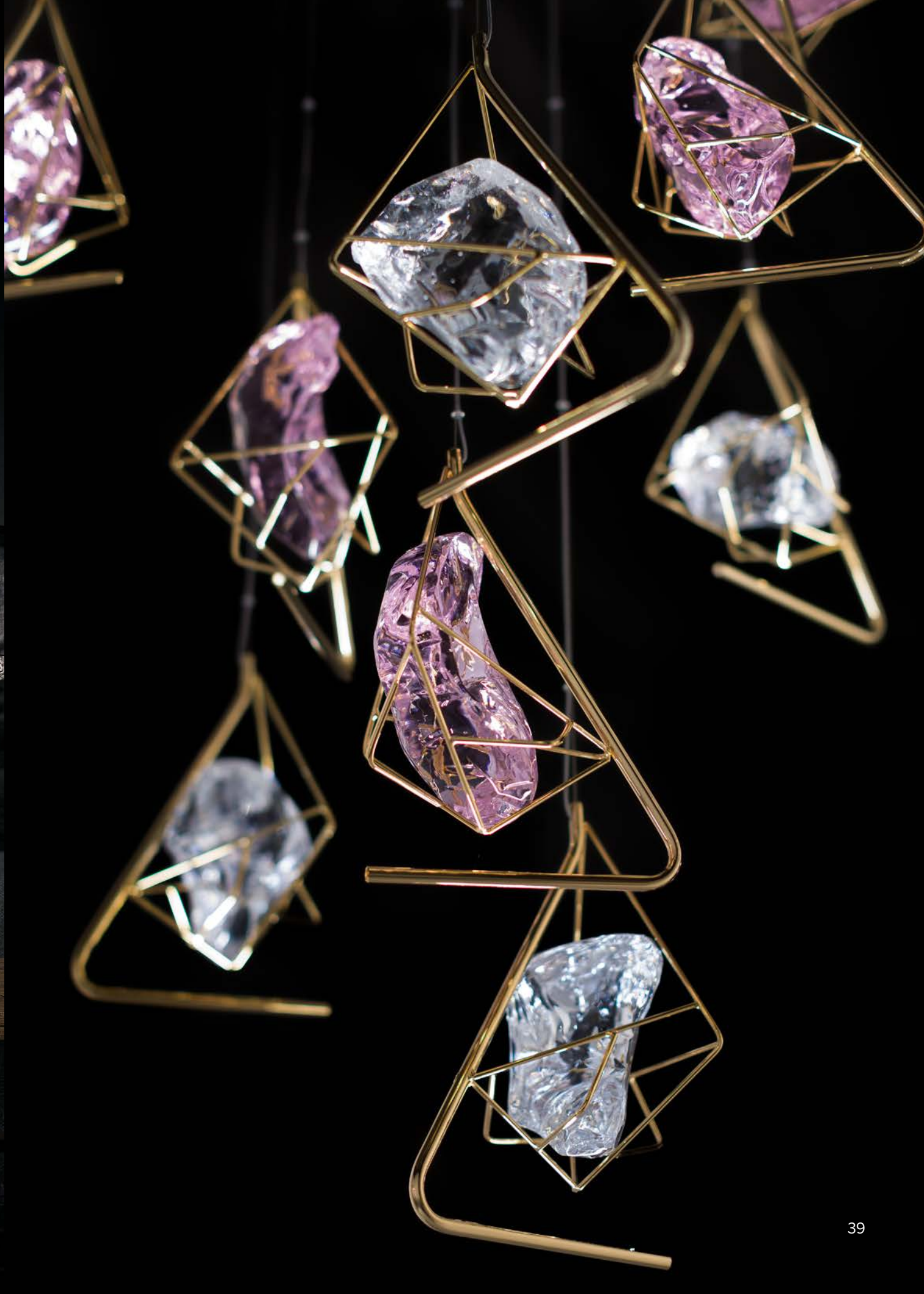



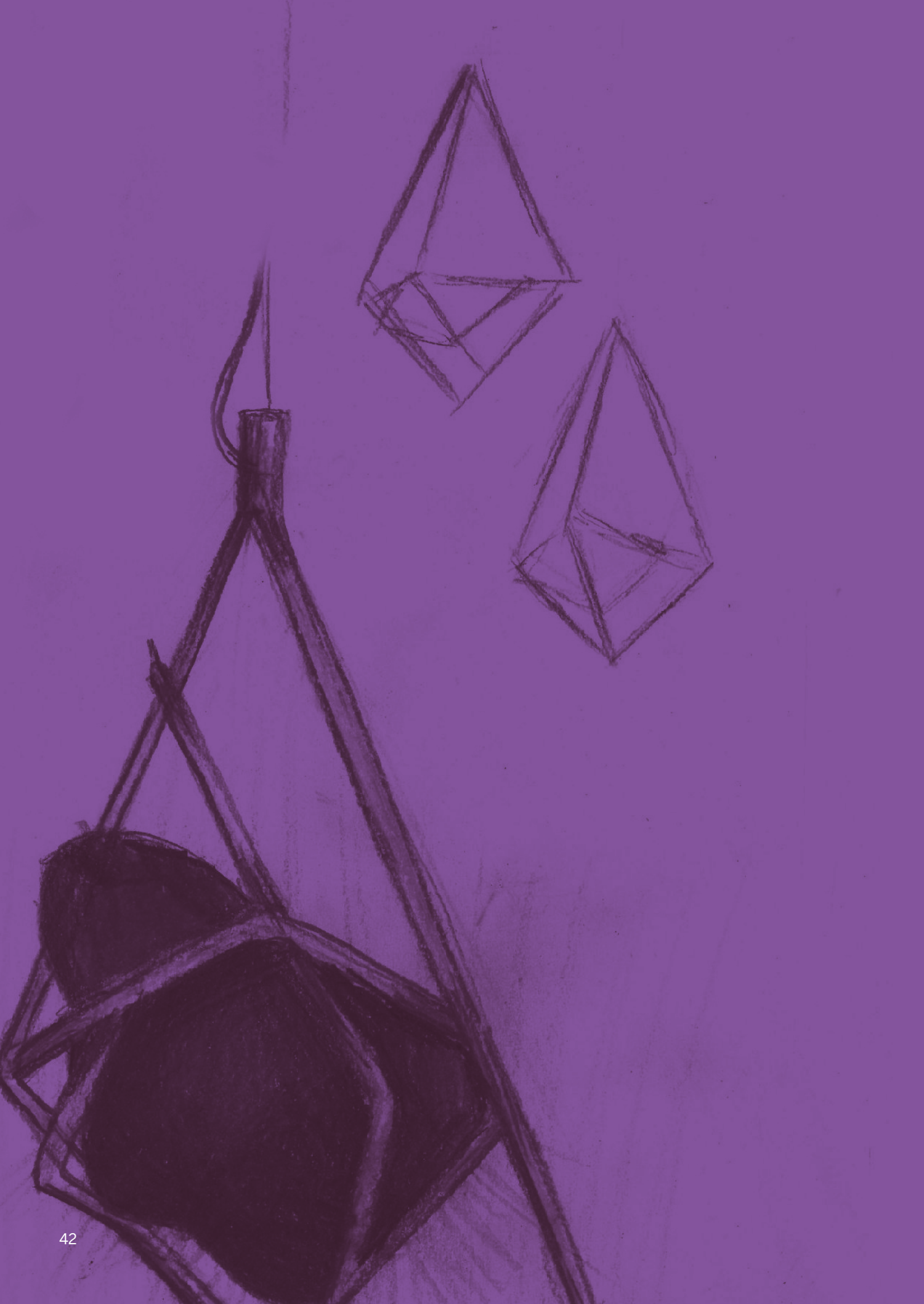





ASTRALBRIDGECASTELC  
RYROCKDUOEFFECTGIRA  
SOLEGLEAMMIKADONEVA  
NOBODYPATCHWORKP  
ROFILEQUADRORAINBOW  
RHYTHMSOUNDVECTOR

Sembrano campane libere nell'aria.  
Un tenue cavetto ne sospende la luce che  
sgorga e si diffonde dai millanta colori delle  
belle calotte leggere. Abbinamenti duali che  
riflettono la poliedricità della personalità.

*They look like bells floating in the air.  
A delicate cable suspends the light that flows  
out of them and spreads from the multitude  
of colours of the beautiful featherlight shades.  
Dual combinations that reflect the versatility  
of the personality.*

**Studio in project**

DESIGN BY  
STUDIO IN PROJECT

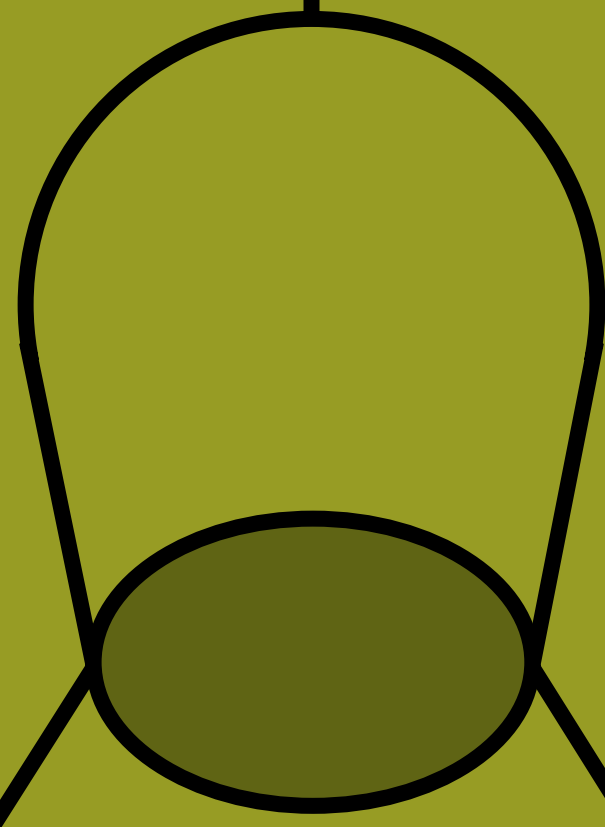

**DUO**



Duo S1 big - S1 small

technical info p. 188

**DUO**



black & gold



lime green & black



dove gray & gold



petrol green & gold



copper & black

ASTRALBRIDGECASTELC  
RYROCKDUO **EFFECT**GIRA  
SOLEGLEAMMIKADONEVA  
NOBODYPATCHWORKP  
ROFILEQUADRORAINBOW  
RHYTHMSOUNDVECTOR

Il disordine dell'universo è apparente.  
Il disordine degli elementi si compone in sublime  
armonia. È l'incanto e la magnificenza della  
creazione.

*The disorder of the universe is apparent.  
The disorder of the elements comes together  
in sublime harmony. The enchantment and  
magnificence of creation.*

**Michele Losito**

DESIGN BY  
MICHELE LOSITO



**VI**  
**EFFECT**







ASTRALBRIDGECASTELC  
RYROCKDUOEFFECTGIRA  
SOLEGLEAMMIKADONEVA  
NOBODYPATCHWORKP  
ROFILEQUADRORAINBOW  
RHYTHMSOUNDVECTOR

Come i girasoli che non si lasciano distrarre e sanno sempre da che parte guardare.

*Like sunflowers that never allow themselves to be distracted and always know which way to look.*

**Nunzia Acquaviva**

DESIGN BY  
NUNZIA ACQUAVIVA

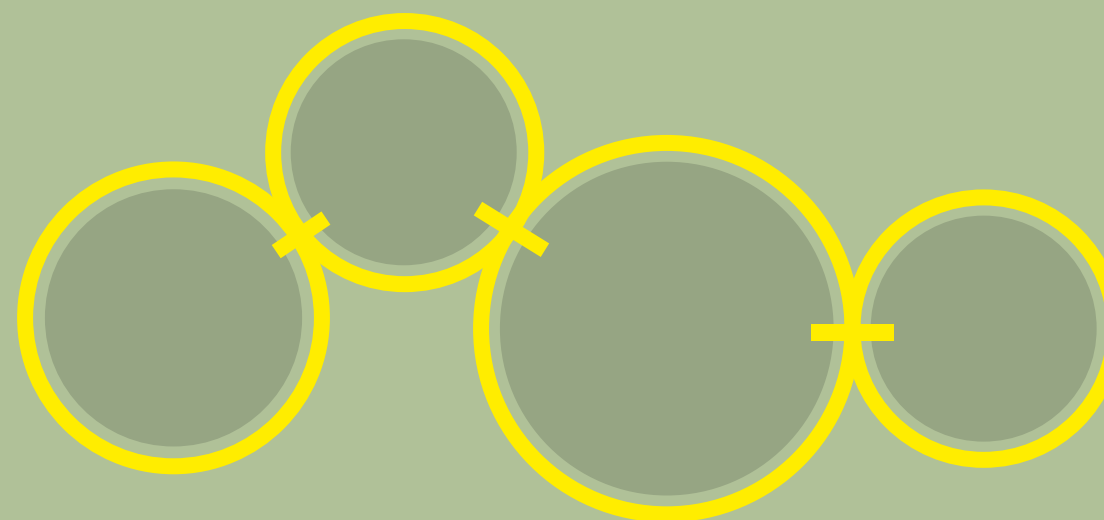

**VII**  
GIRASOLE





GIRASOLE

technical info p. 189

Girasole 20



GIRASOLE

technical info p. 189

Girasole vertical





ASTRALBRIDGECASTELC  
RYROCKDUOEFFECTGIRA  
SOLEGLEAMMIKADONEVA  
NOBODYPATCHWORKP  
ROFILEQUADRORAINBOW  
RHYTHMSOUNDVECTOR

Un fascio di luce, un bagliore che attraversa la perfezione del cristallo riversando lo splendore dei riflessi tutt'intorno. Seducente splendore che incanta.

*A beam of light, a glimmer that penetrates the perfection of the crystal, casting the splendour of the reflections all around. Seductive and enchanting radiance.*

**Studio in project**

DESIGN BY  
STUDIO IN PROJECT

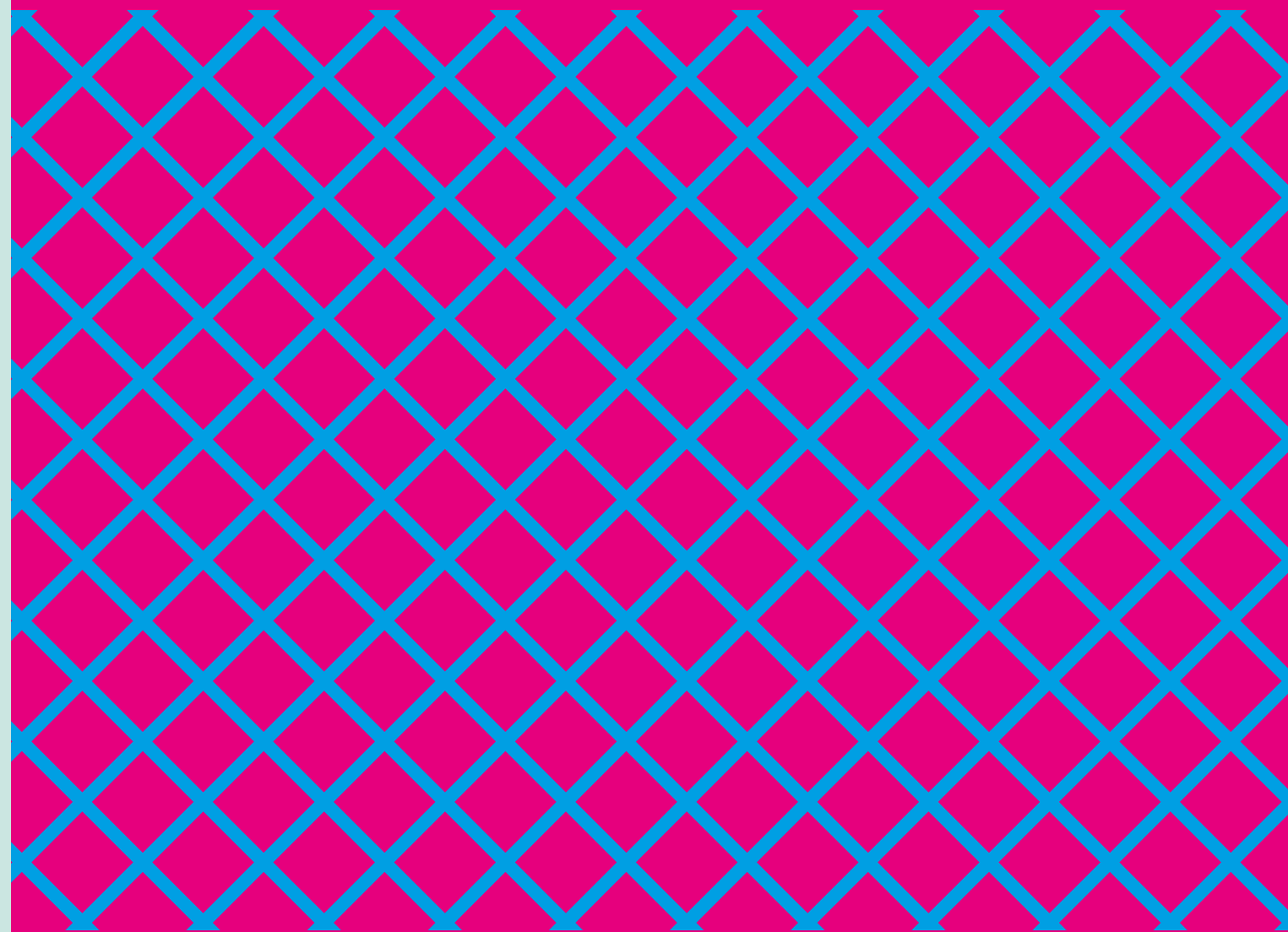

**VIII**  
**GLEAM**









Cleam PT1

technical info p. 190

**GLEAM**



ASTRALBRIDGECASTELC  
RYROCKDUOEFFECTGIRA  
SOLEGLEAMMIKADONEVA  
NOBODYPATCHWORKP  
ROFILEQUADRORAINBOW  
RHYTHMSOUNDVECTOR

Un intreccio di elementi, un groviglio che pian piano, con la giusta attenzione precisione e meditazione si dispiega.

*A jumble of elements, a tangle which, thanks to just the right amount of attention, precision and meditation, slowly unravels.*

**Nunzia Acquaviva**

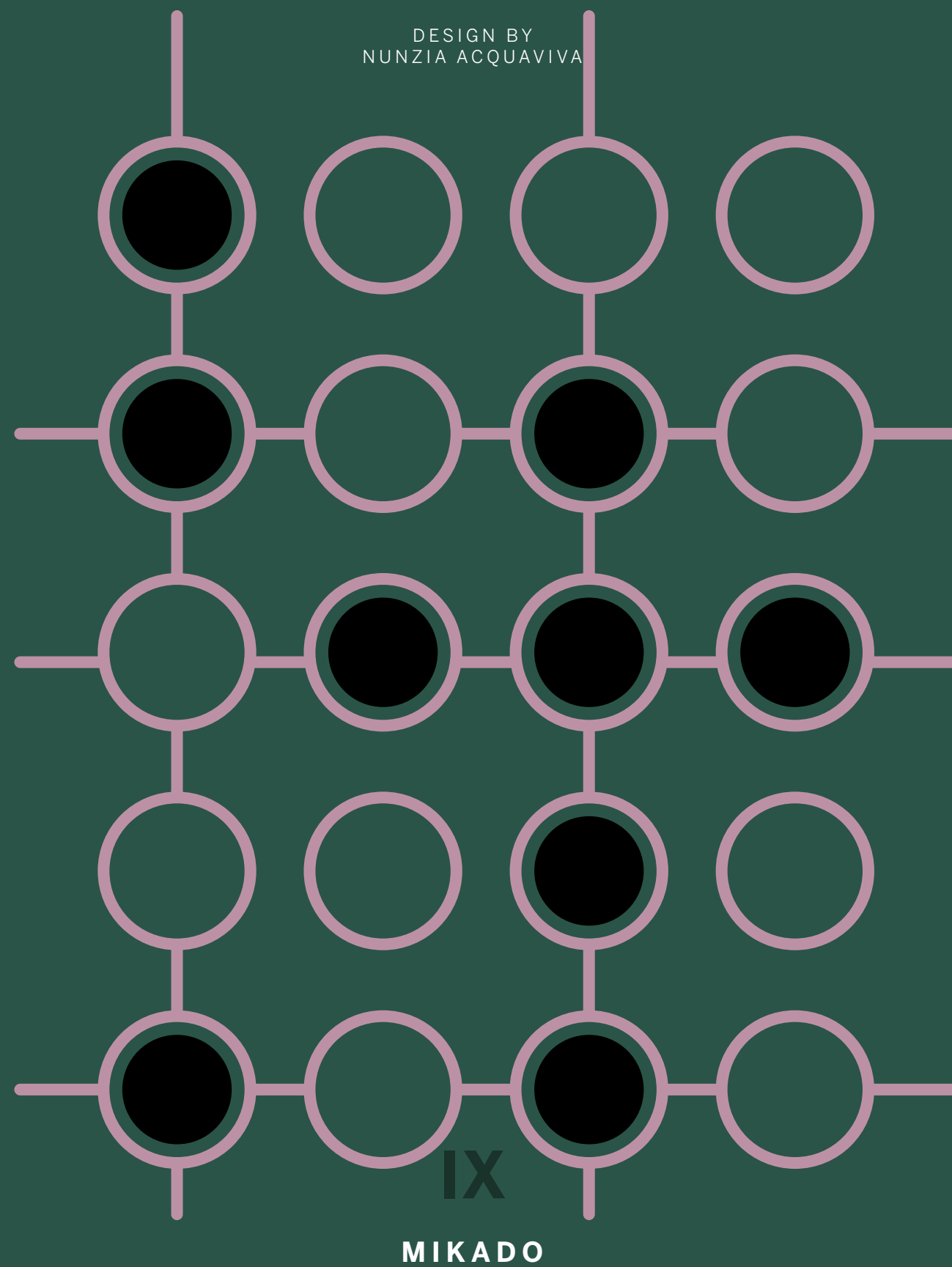

**MIKADO**

technical info p. 191

Mikado horizon

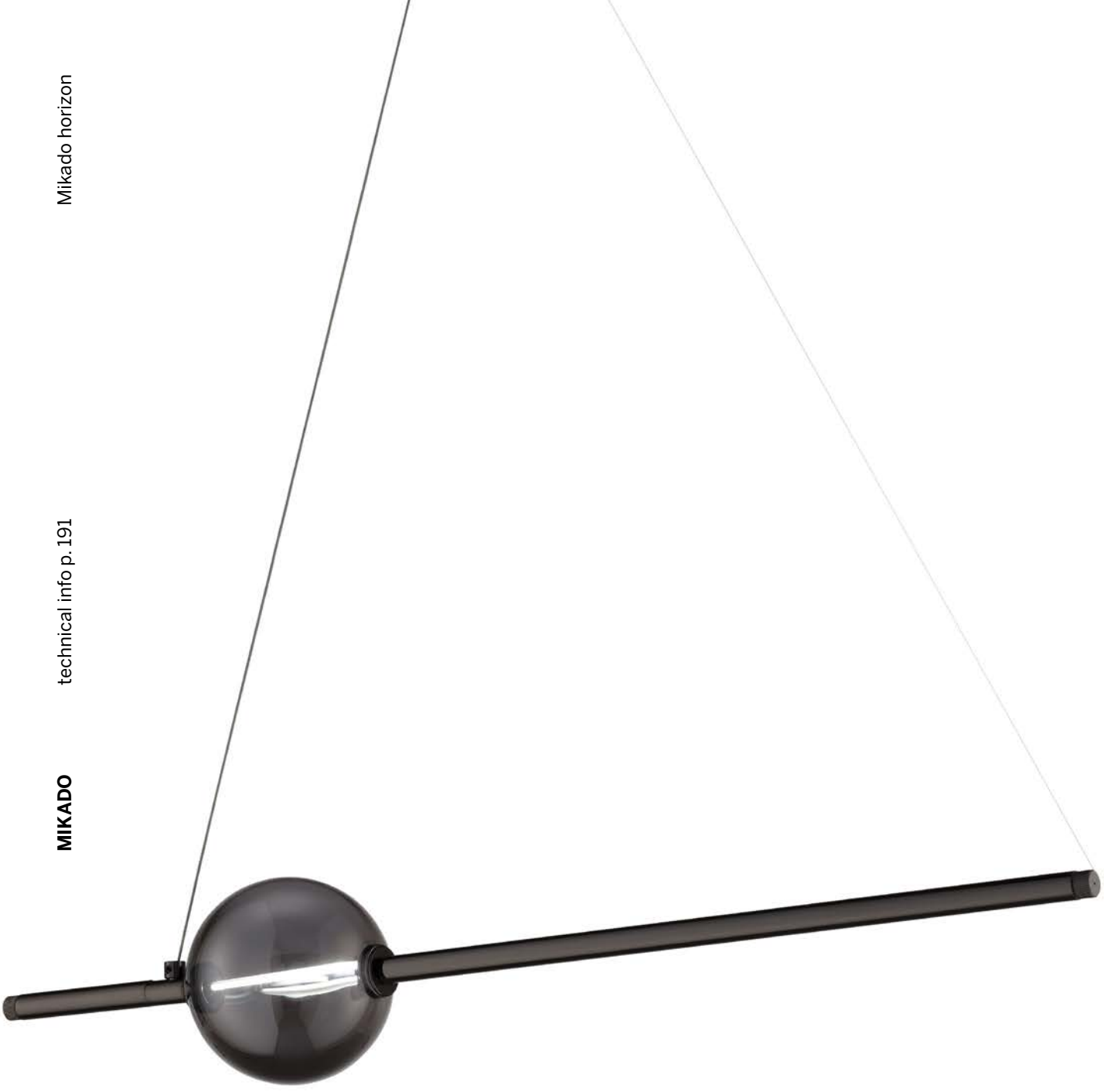

**MIKADO**

technical info p. 191

Mikado in & out

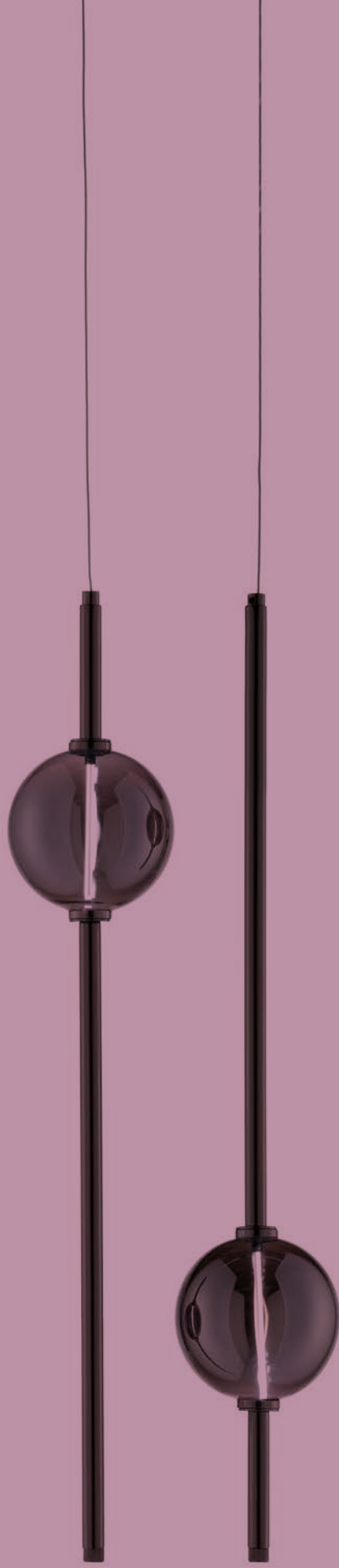





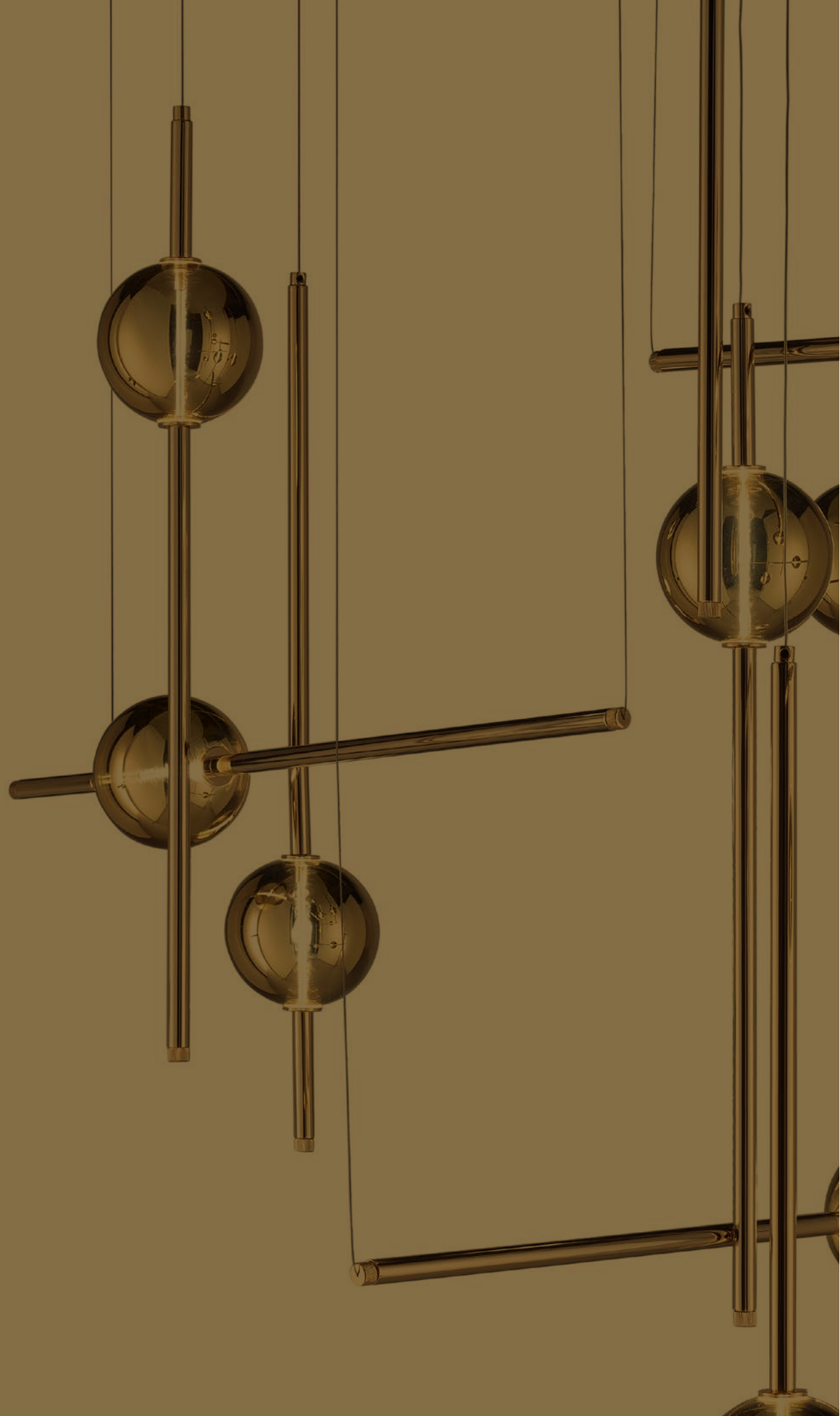



ASTRALBRIDGECASTELC  
RYROCKDUOEFFECTGIRA  
SOLEGLEAMMIKADONEVA  
NOBODYPATCHWORKP  
ROFILEQUADRORAINBOW  
RHYTHMSOUNDVECTOR

Un gruppo di lunghi ghiaccioli sospesi al tetto di una casa attraversati dalla bassa luce solare che infrange il ghiaccio creando un gioco cristallino di luce. Ecco fissato questo momento fugace per trasferirlo nello spazio di un'abitazione. Una sottile montatura in metallo crea il riferimento alla natura senza distrarre troppo dal gioco di luce dei vetri.

*A group of long icicles suspended from the roof of a house crossed by low sunlight that shatters the ice, creating a crystal-clear pattern of light. This fleeting moment is frozen in time and transferred into the space of a home. A thin metal frame creates a reference to nature without distracting too much from the lighting effect created by the glass.*

**Daniel Becker**

DESIGN BY  
DANIEL BECKER

X

NEVA



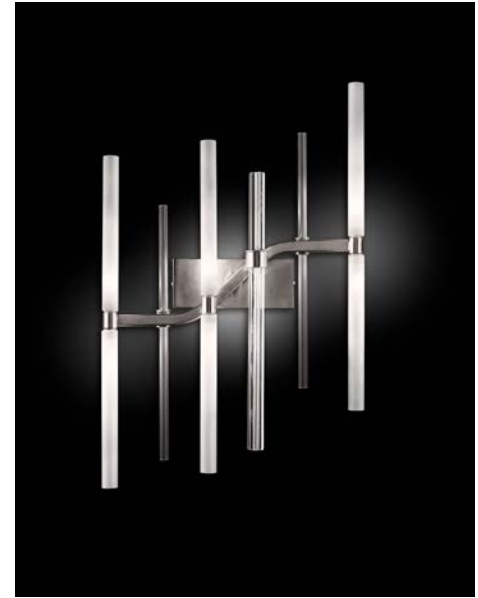

ASTRALBRIDGECASTELC  
RYROCKDUOEFFECTGIRA  
SOLEGLEAMMIKADONEVA  
NOBODYPATCHWORKP  
ROFILEQUADRORAINBOW  
RHYTHMSOUNDVECTOR

Nobody è un'entità astratta, sostanza senza corpo: una sfera in metallo libera di essere orientata nello spazio. Soltanto un'esile ed eterea struttura la sostiene dal soffitto facendola galleggiare a mezz'aria.

Nobody, "Nessuno", è anche un riferimento omerico, un omaggio all'astuzia di Ulisse che riuscì a sfuggire dalla grotta del gigante con un solo occhio Polifemo dicendo di chiamarsi Nessuno: il diffusore dell'apparecchio infatti può essere inteso come un singolo occhio da direzionare a piacere.

*Nobody is an abstract entity, substance without body: a metal sphere free to move through space. Only a slender and ethereal structure supports it from the ceiling, making it float in mid-air.*

*Nobody is also a Homeric reference, a tribute to the cunning of Ulysses who succeeded in escaping from the cave of the one-eyed giant Polyphemus by telling him his name was Nobody: the diffuser of the light fitting can be intended as a single eye to be positioned as desired.*

**Alberto Ghirardello**

DESIGN BY  
ALBERTO GHIRARDELLO

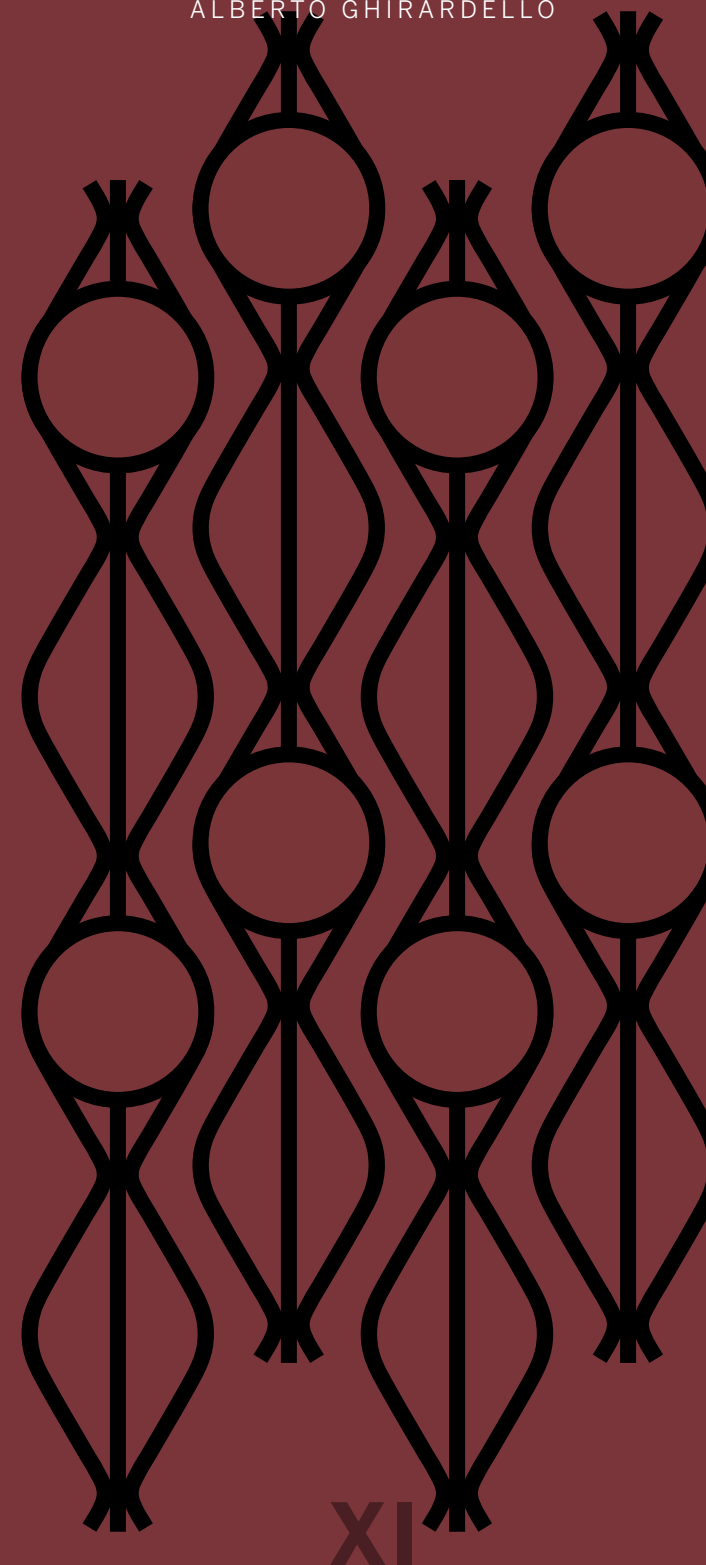

XI

**NOBODY**





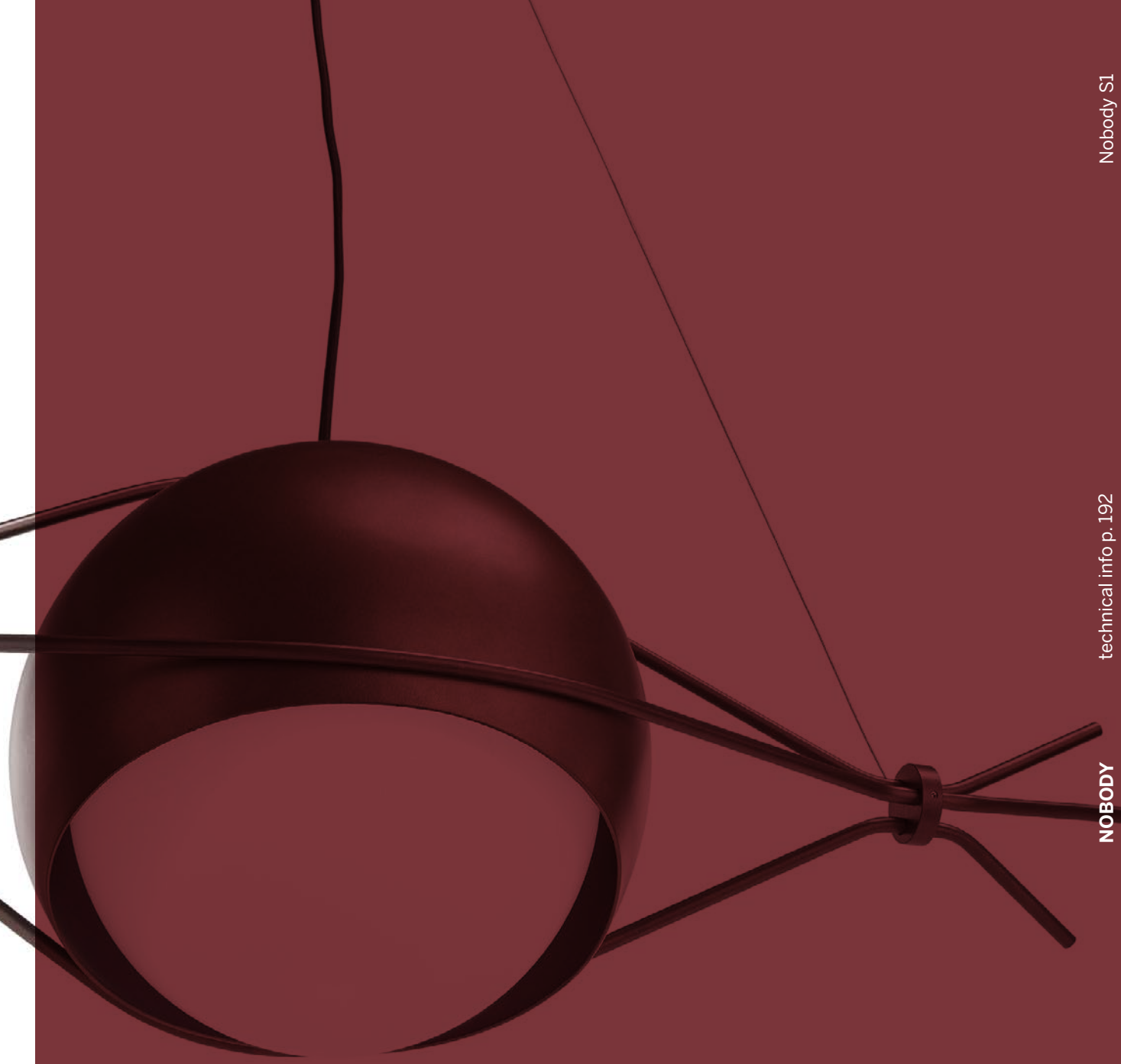

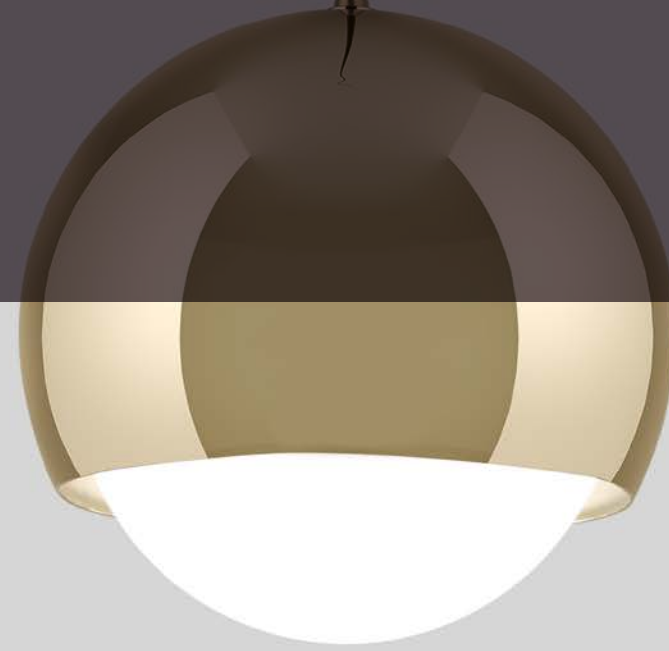



ASTRALBRIDGECASTELC  
RYROCKDUOEFFECTGIRA  
SOLEGLEAMMIKADONEVA  
NOBODYPATCHWORKP  
ROFILEQUADRORAINBOW  
RHYTHMSOUNDVECTOR

Semplici griglie di metallo alloggiano al loro interno diversi "ritagli" di vetro, dando vita ad un vero e proprio patchwork di trasparenze, luce e riflessi.

*Simple metal grids house several glass "cut-outs", creating a real patchwork of transparencies, light and reflections*

**Sovrappensiero Studio**

DESIGN BY  
SOVRAPPENSIERO

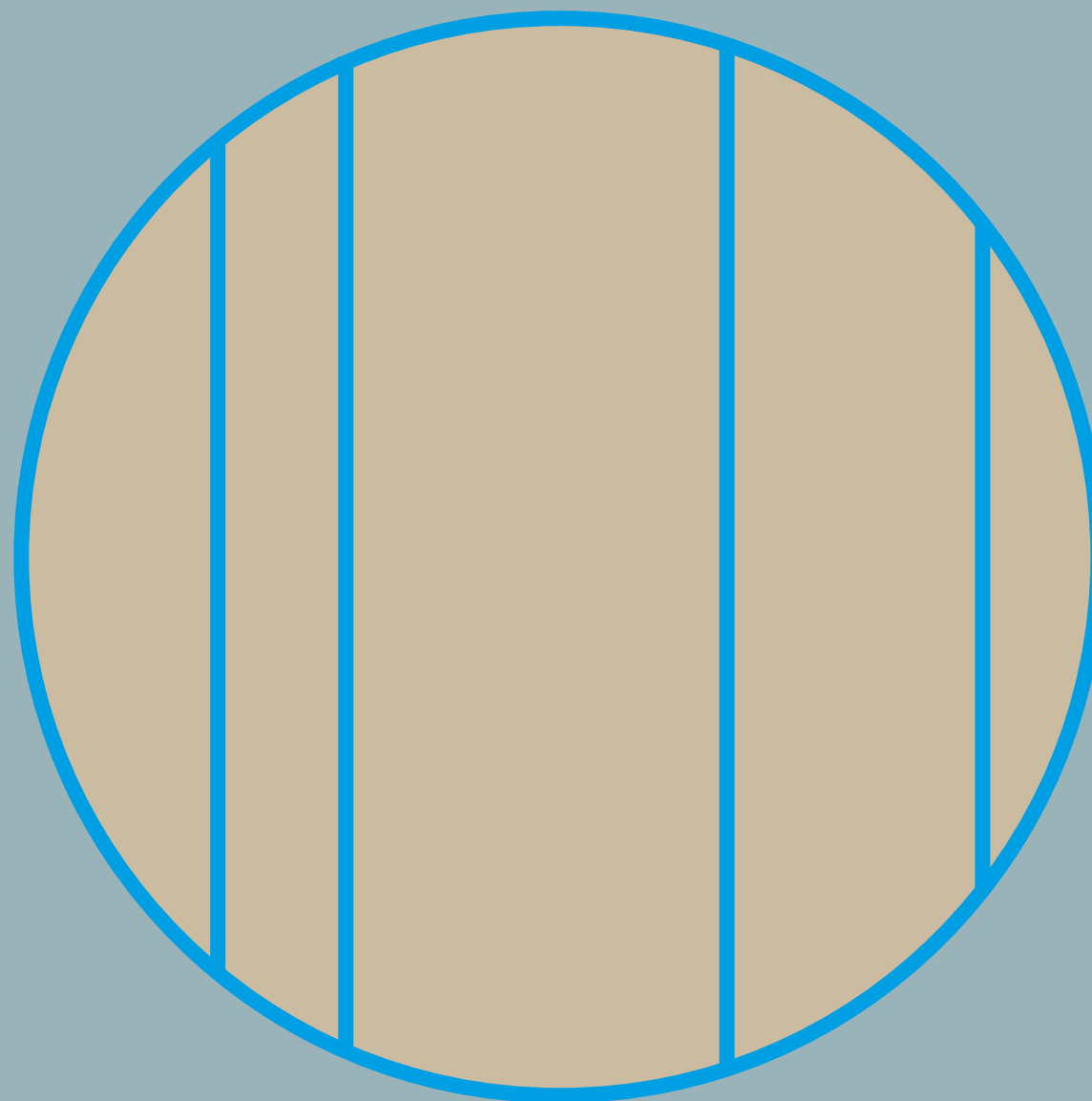

XII  
PATCHWORK









ASTRALBRIDGECASTELC  
RYROCKDUOEFFECTGIRA  
SOLEGLEAMMIKADONEVA  
NOBODYPATCHWORKP  
ROFILEQUADRORAINBOW  
RHYTHMSOUNDVECTOR

Il minimalismo che si materializza in una linea.  
Il tratto essenziale che, però, connota in maniera sostanziale l'espressione.

*Minimalism that materialises in a line. The basic stroke that substantially characterises the expression.*

**Studio in project**

DESIGN BY  
STUDIO IN PROJECT

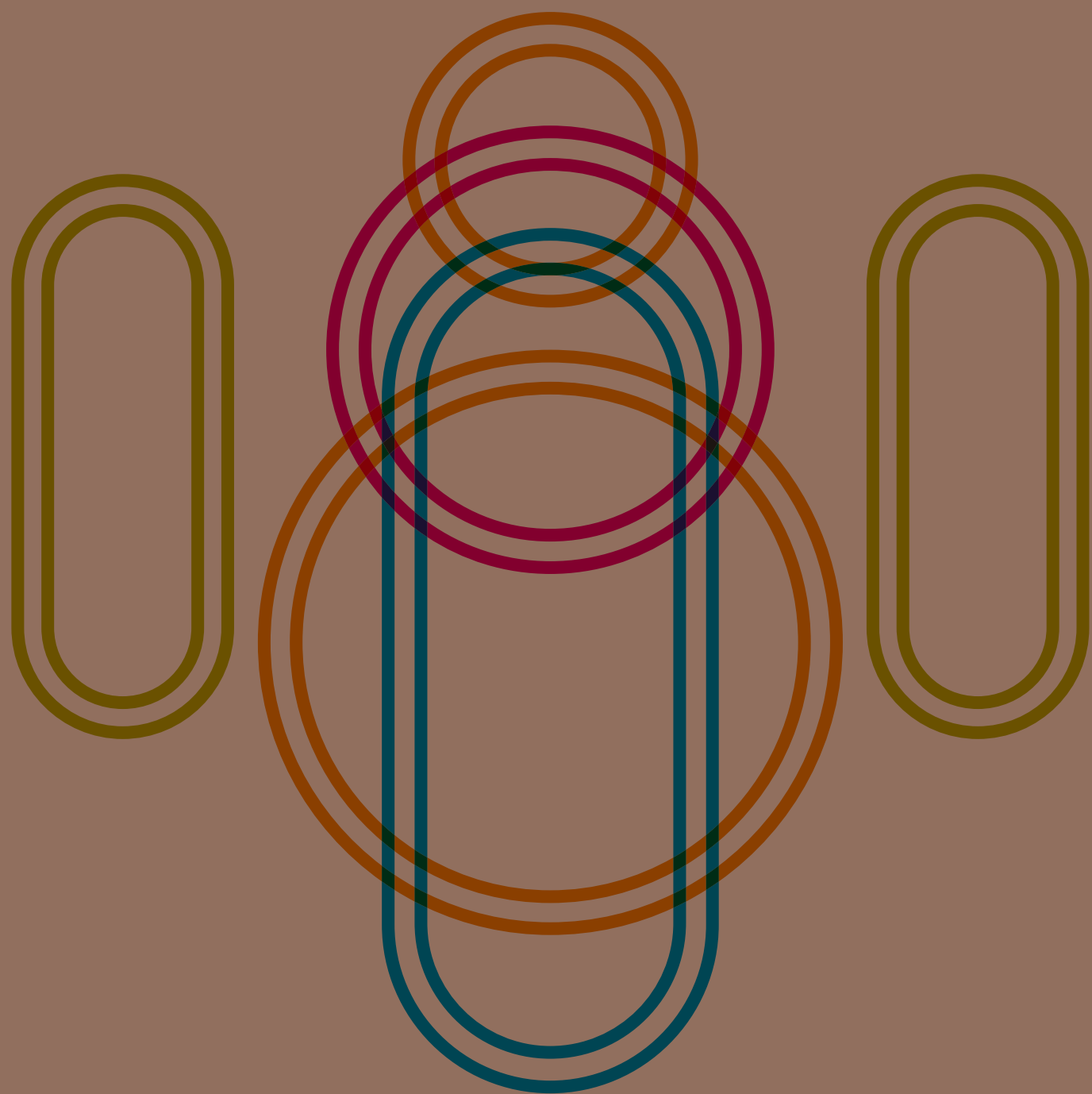

XIII  
PROFILE

**PROFILE**

technical info p. 194

Profile oval 180x40

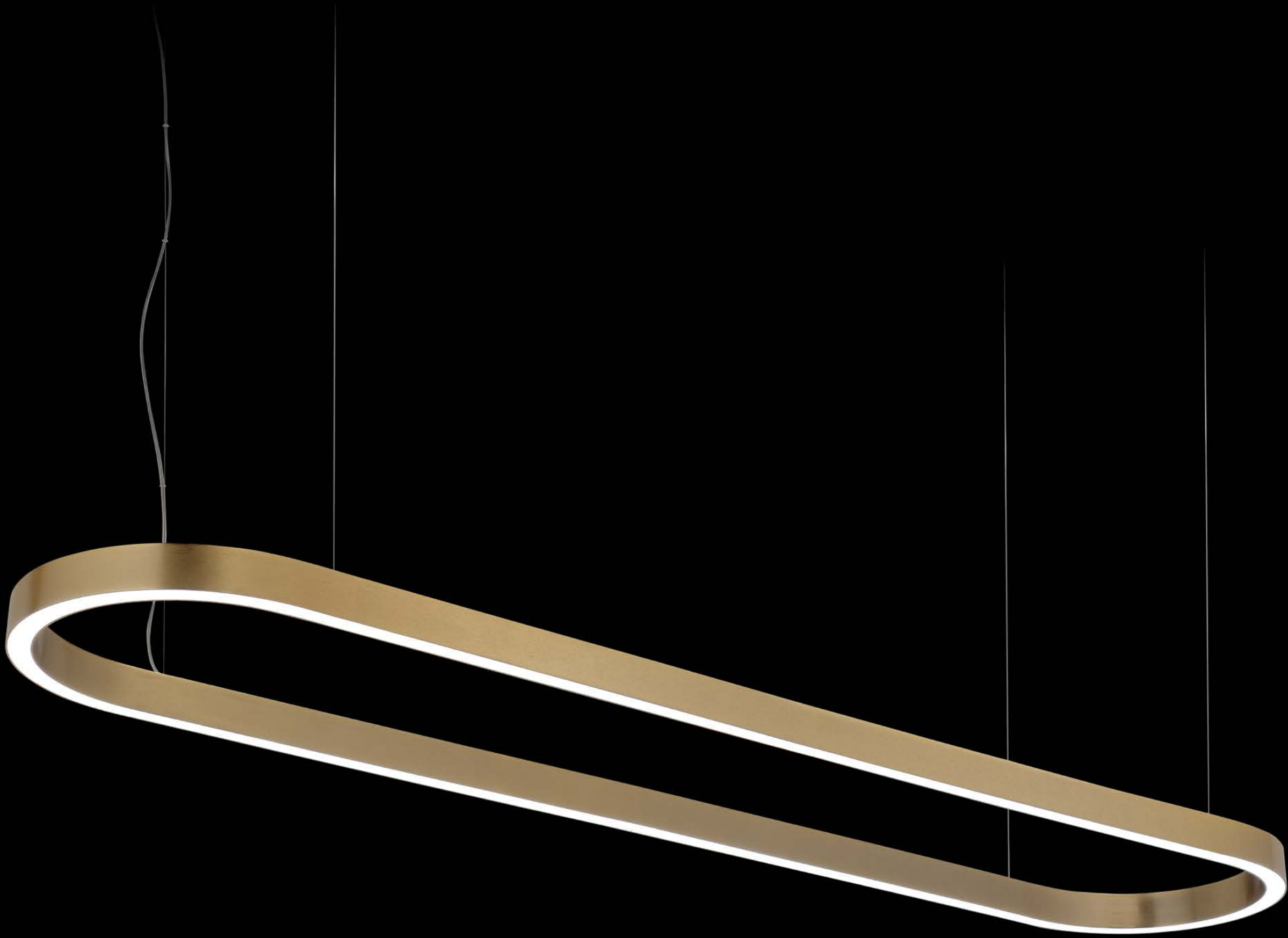

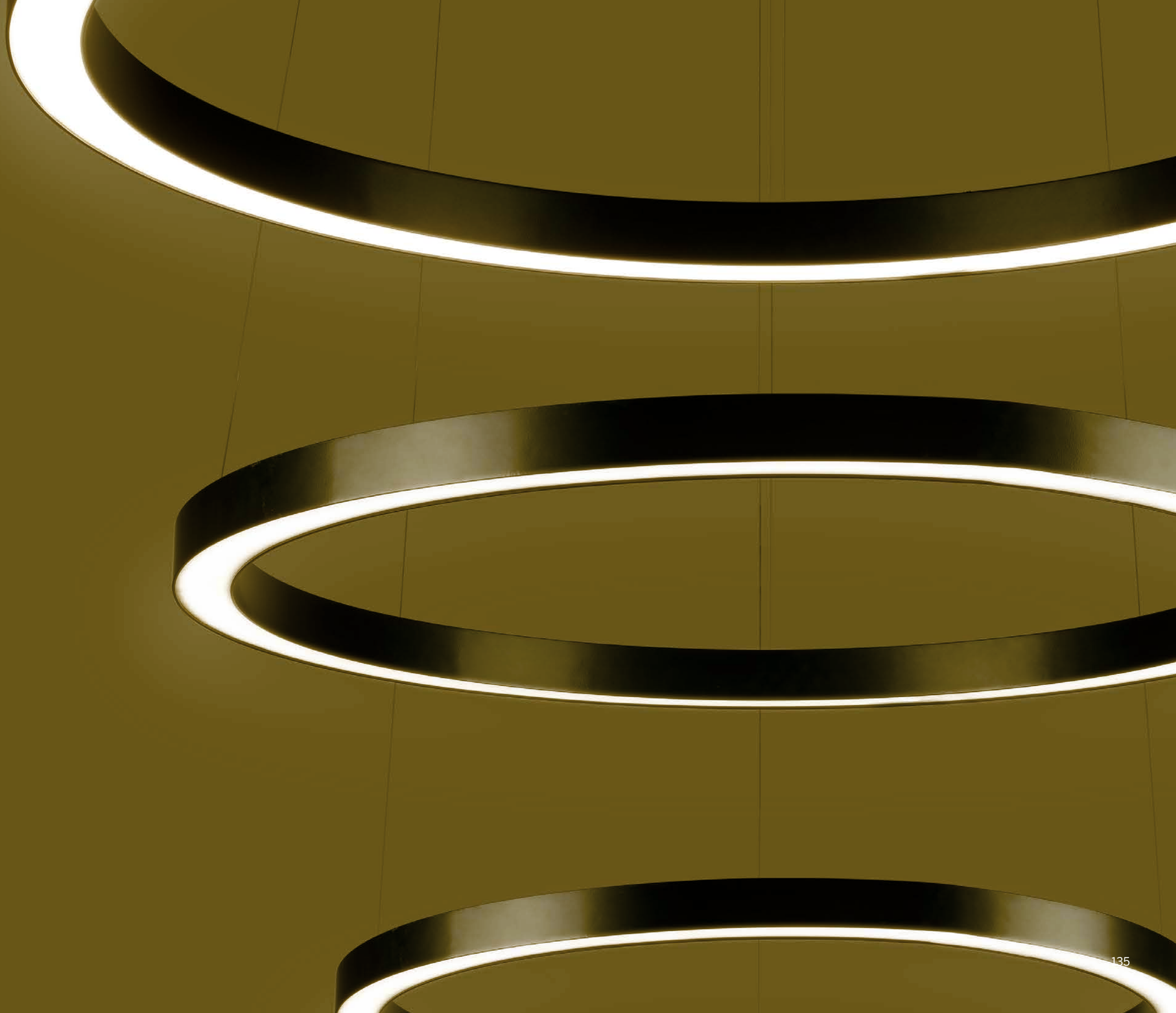



ASTRALBRIDGECASTELC  
RYROCKDUOEFFECTGIRA  
SOLEGLEAMMIKADONEVA  
NOBODYPATCHWORKP  
ROFILEQUADRORAINBOW  
RHYTHMSOUNDVECTOR

Ispirarsi all'arte è dare certezza alla bellezza.  
Un quadro ispira, arreda e illumina.

*Being inspired by art means conveying  
certainty to beauty.  
A painting inspires, furnishes and illuminates.*

**Michel Losito**

DESIGN BY  
MICHELE LOSITO

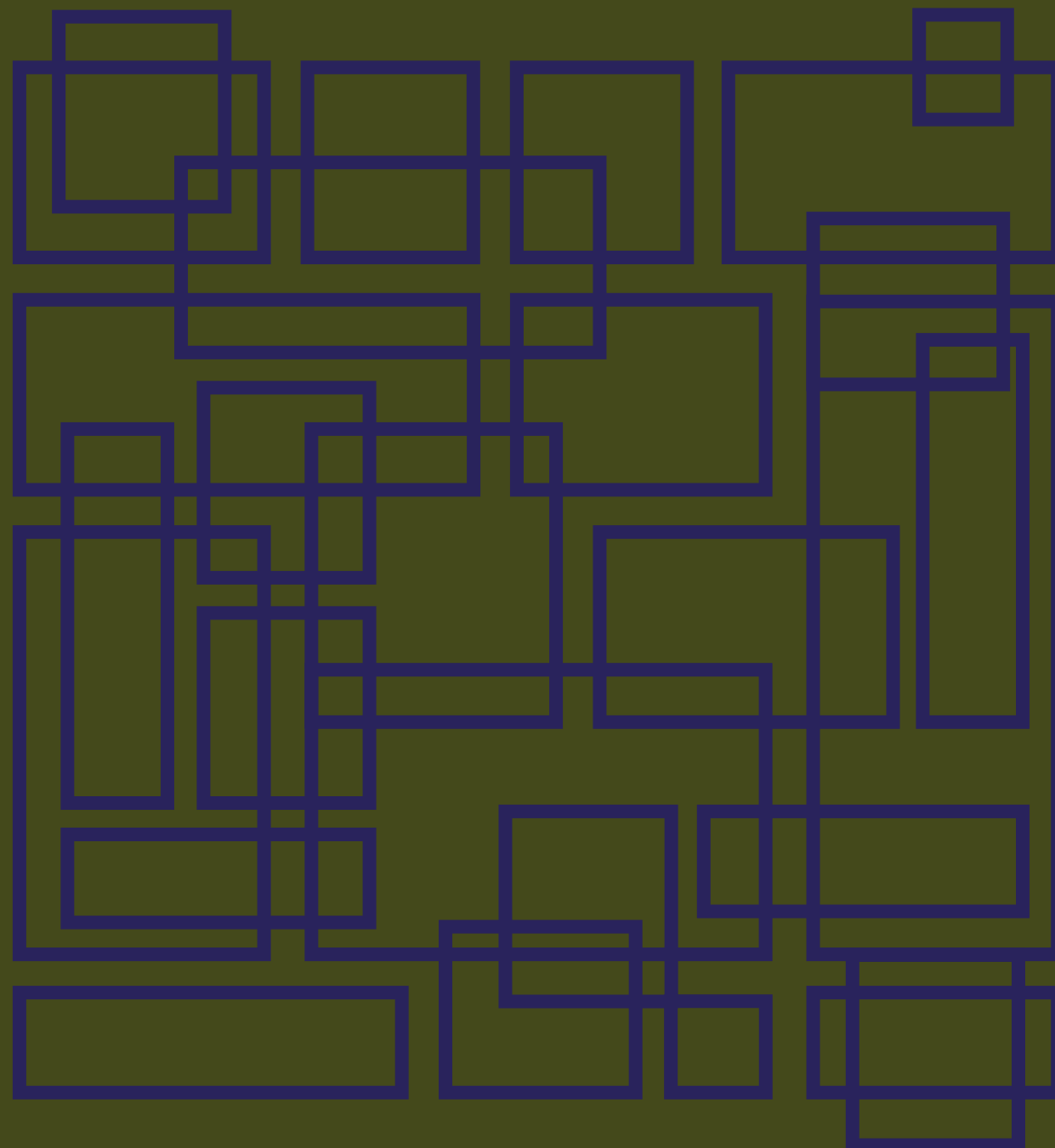

**XIV**  
**QUADRO**





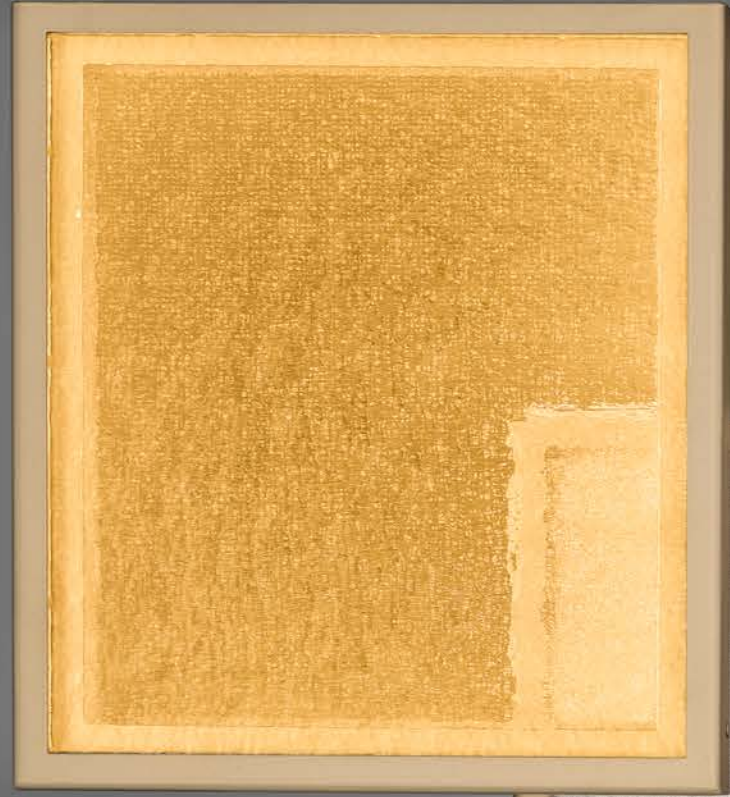

ASTRALBRIDGECASTELC  
RYROCKDUOEFFECTGIRA  
SOLEGLEAMMIKADONEVA  
NOBODYPATCHWORKP  
ROFILEQUADRO**RAINBOW**  
RHYTHMSOUNDVECTOR

Giocare con i colori, mescolarli come se si stesse disegnando per la prima volta: prende corpo l'arcobaleno.

*Play with colours, mix them as if you were drawing for the first time: the rainbow takes shape.*

**Studio in project**

DESIGN BY  
STUDIO IN PROJECT

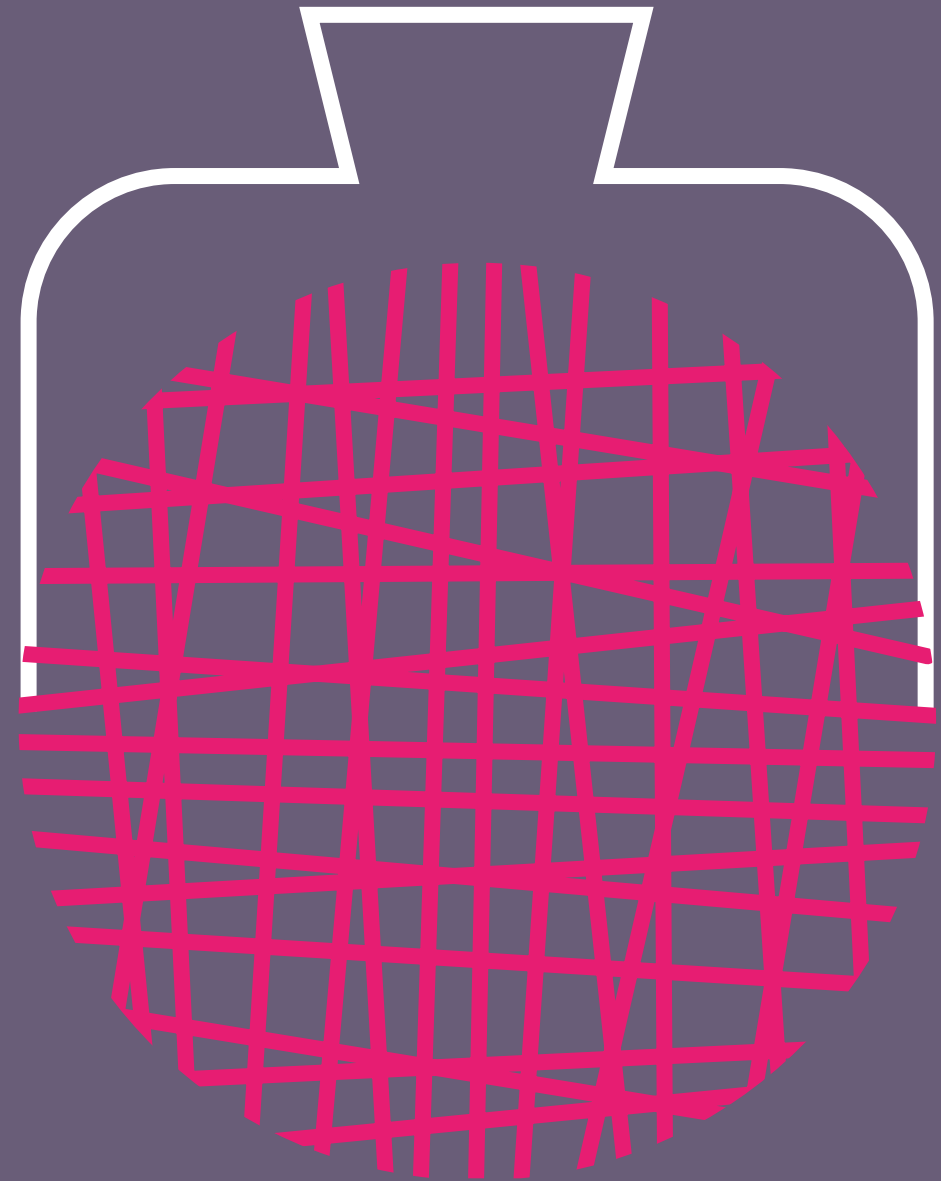

XV

RAINBOW



aquamarine



blue



brown



ASTRALBRIDGECASTELC  
RYROCKDUOEFFECTGIRA  
SOLEGLEAMMIKADONEVA  
NOBODYPATCHWORKP  
ROFILEQUADRORAINBOW  
RHYTHMSOUNDVECTOR

Forme in movimento, alternanza di suoni o di momenti di luce e ombra, di azioni e pause: sorprendersi a pensare quando tutto sembra così lineare.

*Shapes in motion, alternating sounds or moments of light and shade, actions and pauses: surprise yourself by thinking when everything seems so linear.*

**Michele Losito**

DESIGN BY  
MICHELE LOSITO

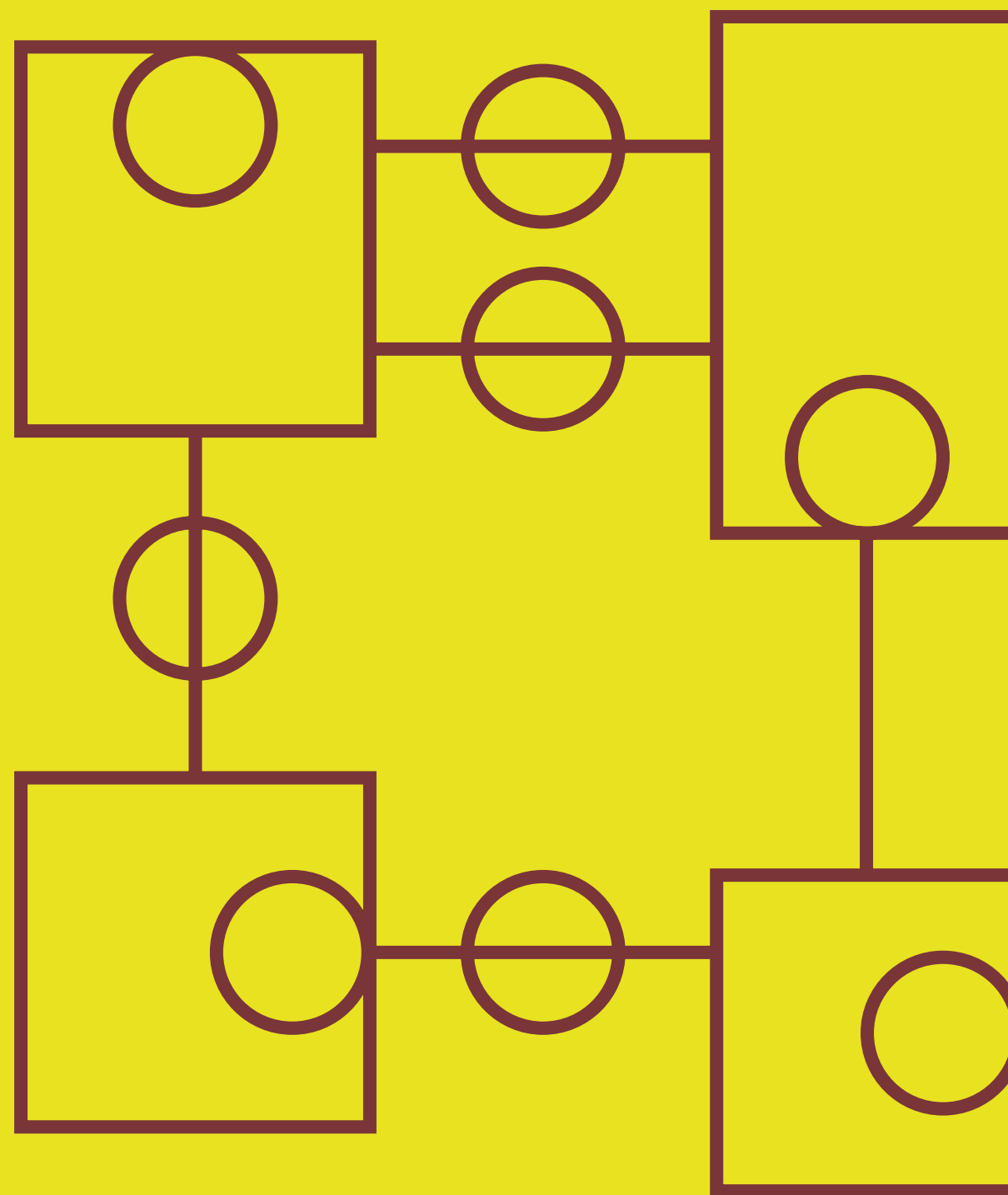

XVI

RHYTHM



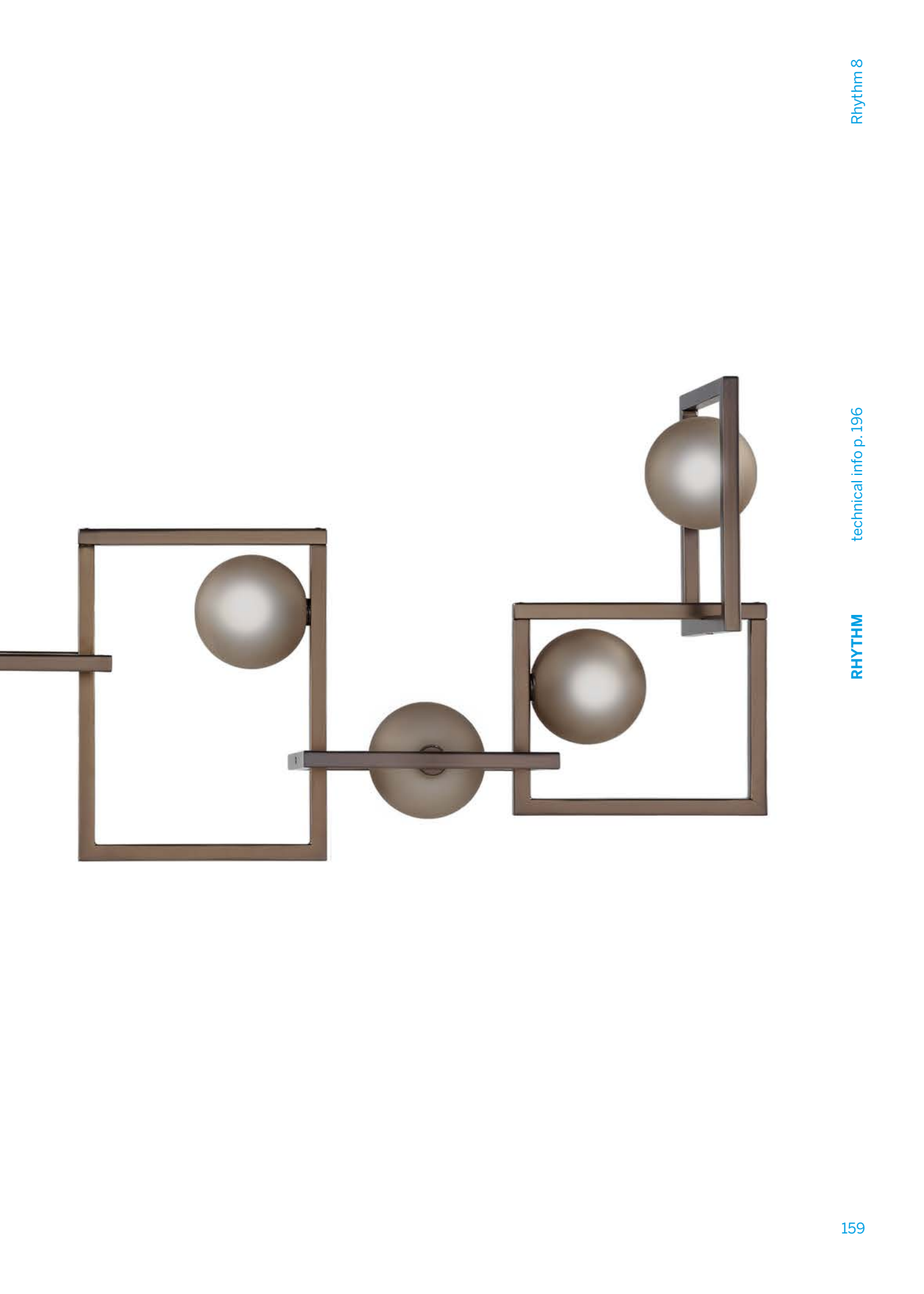
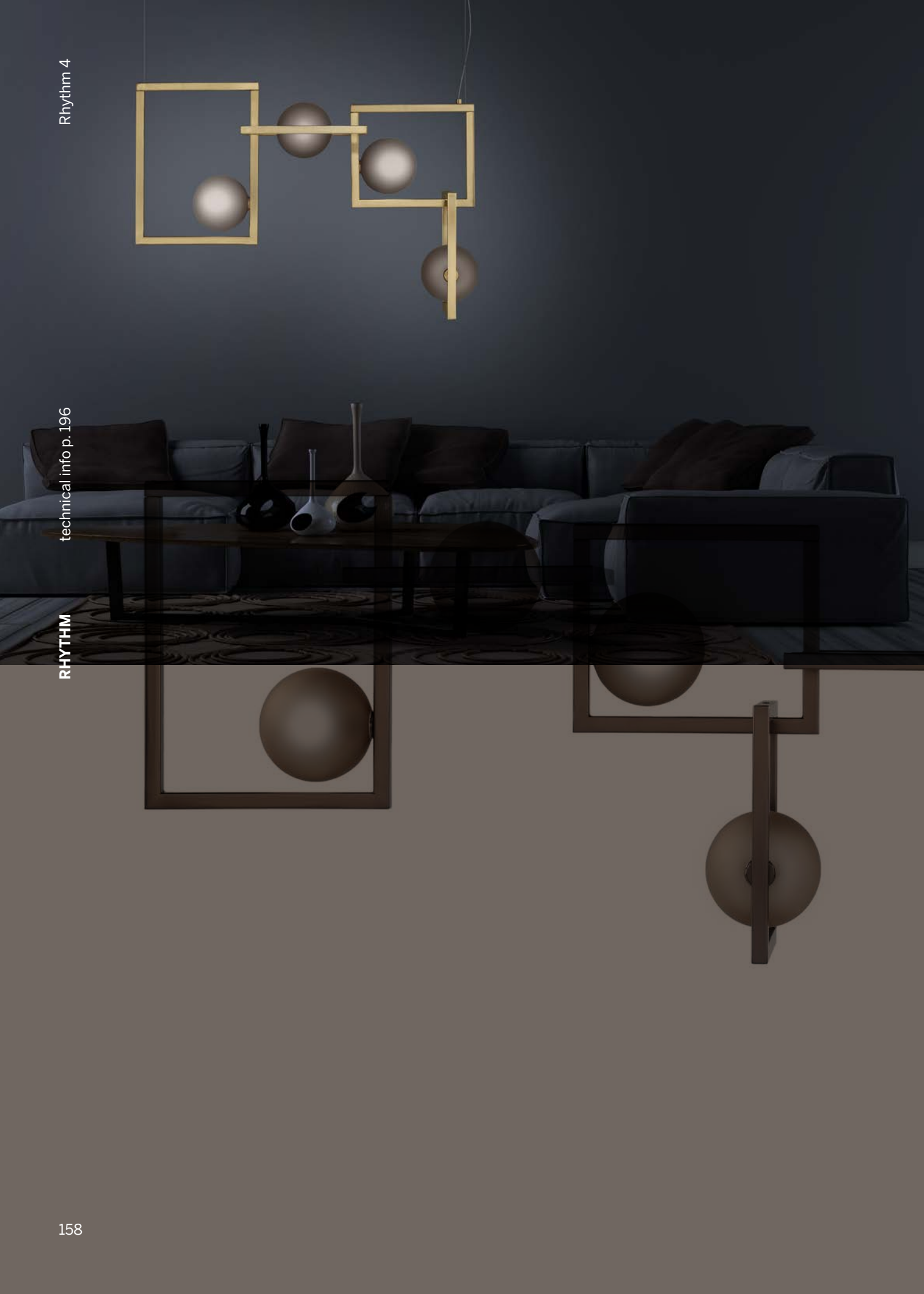



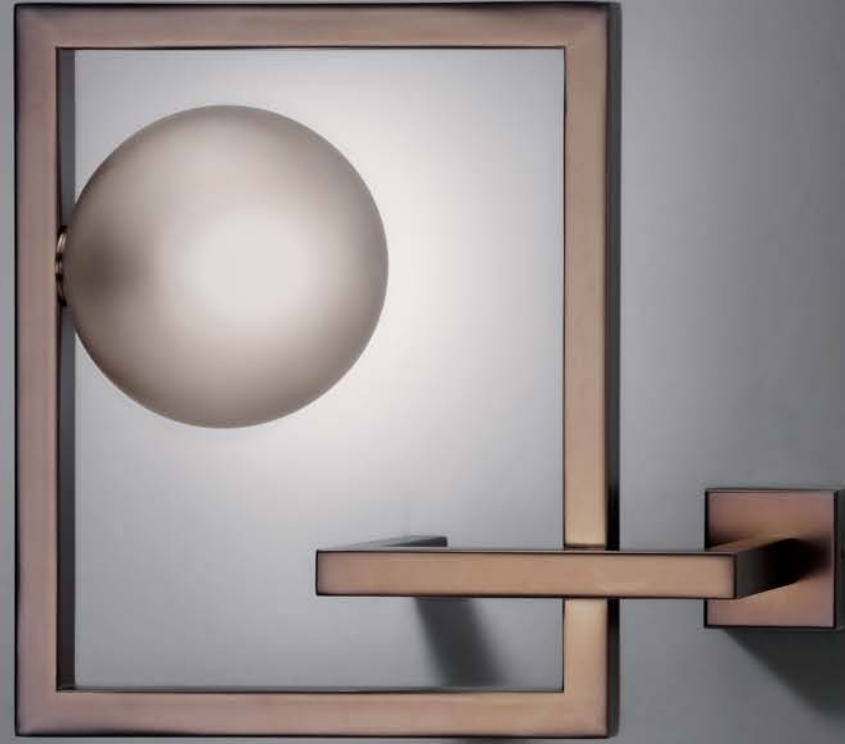

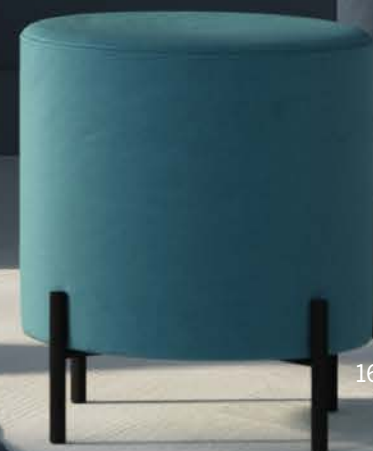

ASTRALBRIDGECASTELC  
RYROCKDUOEFFECTGIRA  
SOLEGLEAMMIKADONEVA  
NOBODYPATCHWORKP  
ROFILEQUADRORAINBOW  
RHYTHMSOUNDVECTOR

È come sentire la voce di Frank Sinatra in "My Way" o quella della Queen of Soul Aretha Franklin in "Think".

*It's like hearing Frank Sinatra's voice in "My Way" or that of the Queen of Soul, Aretha Franklin, in "think".*

**Michele Losito**

DESIGN BY  
MICHELE LOSITO



**XVII**  
SOUND



ASTRALBRIDGECASTELC  
RYROCKDUOEFFECTGIRA  
SOLEGLEAMMIKADONEVA  
NOBODYPATCHWORKP  
ROFILEQUADRORAINBOW  
RHYTHMSOUNDVECTOR

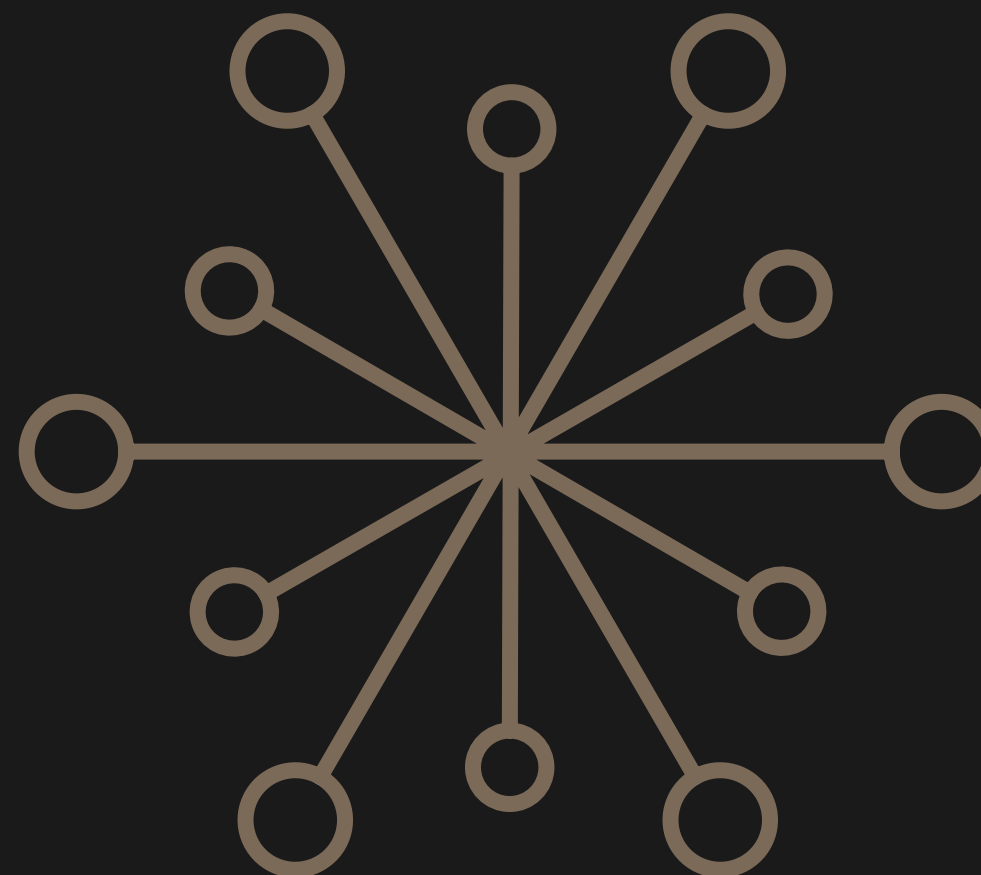

Figure geometriche che si rincorrono, segmenti di metallo si librano nelle tre dimensioni dello spazio, spigoli, direzioni che assume la quotidianità.

*Geometrical figures that chase each other, metal segments that hover in the three dimensions of space, and the edges formed and directions taken by everyday life.*

**Nunzia Acquaviva**

DESIGN BY  
NUNZIA ACQUAVIVA



**XVIII**

**VECTOR**









**TECHNICAL INFO**

# ASTRAL

design by Studio in project

**Finitura** | oro satinato, alluminio anodizzato. Altre finiture su richiesta.

**Colori** | dischetto opalino. Altri colori su richiesta.

**Particolari** | faretto realizzato su nostro disegno.

Astral è già disponibile nelle misure indicate nei disegni. Non esitate a contattarci per differente richiesta. Verrà realizzato un progetto esclusivo che si adatti al meglio ai vostri spazi e soddisfi le Vostre esigenze.

**Finish** | satin gold, anodized aluminum. Other finishes on request.

**Color** | disk in opal color. Other colors on request.

**Details** | spotlights are produced handmade on our drawing.

Astral is already available with sizes as technical drawings.

Don't hesitate to contact us for any request or different size.

We will create an exclusive project for your spaces and for your needs.

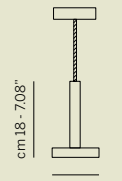
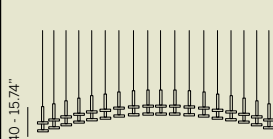
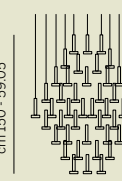
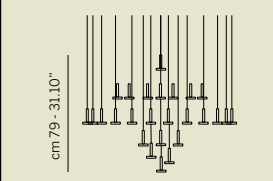
 <p>cm 18 - 7.08" Ø cm 6 - 2.36"</p>	<p><b>ASTRAL S1</b> 1 spot led 3W - 4000°K - 12 Vdc 280 lm</p> <p>Aggancio con cavo di alimentazione (D). Hook with power cord (D).</p> <p>metalli / metal</p>	 <p>cm 40 - 15.74" cm 370 x cm 70 - 145.66" x 27.55"</p>	<p><b>ASTRAL PROJECT 84</b> 84 spot led 252W - 4000°K 12 Vdc - 23520 lm</p> <p>Aggancio con cavo di alimentazione (D). Hook with power cord (D).</p> <p>metalli / metal</p>
 <p>cm 150 - 59.05" Ø cm 110 - 43.30"</p>	<p><b>ASTRAL CHANDELIER 133</b> 133 spot led 399W - 4000°K 12 Vdc - 37240 lm</p> <p>Aggancio con cavo di alimentazione (D). Hook with power cord (D).</p> <p>metalli / metal</p>	 <p>cm 79 - 31.10" Ø cm 100 - 39.37"</p>	<p><b>ASTRAL CHANDELIER 52</b> 52 spot led 156W - 4000°K 12 Vdc - 14560 lm</p> <p>Aggancio con cavo di alimentazione (D). Hook with power cord (D).</p> <p>metalli / metal</p>

# BRIDGE

design by Nunzia Acquaviva

**Finitura** | RAL nero opaco. Altre finiture su richiesta

**Colori** | vetro curvato nei colori trasparente satinato, acquamarina satinato, verde diamond satinato, ambra satinato. Altri colori su richiesta.

**Particolari** | struttura realizzata artigianalmente su nostro disegno.

Vetro in piastra effetto corteccia e curvato made in Veneto.

Per qualsiasi richiesta o differente versione non esitate a contattarci.

**Finish** | RAL matt black. Other finishes on request.

**Color** | the curved glass in satin transparent color, in satin aquamarine color, in satin diamond green color, in satin amber color. Other colors on request.

**Details** | the structure is produced handmade on our drawing. The curved glass with bark effect is made in Veneto. Don't hesitate to contact us for any request or different version.

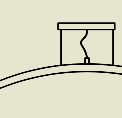
 <p>cm 14 - 5.51" cm 70 x cm 10 - 27.5" x 3.93"</p>	<p><b>BRIDGE 70</b> 1 strip led 30W - 4000°K 24 Vdc - 1200 lm</p> <p>Aggancio con tiranti per sospensioni (C) Hook with metal cables for suspensions (C)</p> <p>vetri / glass</p> <p>metalli / metal</p>
--	--

# CASTEL

design by Vincenzo Bafunno

**Finitura** | oro satinato, cromo satinato, cromo lucido, RAL bianco opaco. Altre finiture su richiesta.

**Colori marmo** | basi varianti: forest green, royal daino beige, marquinia black, spaider white, mystic brown, amazing grey.

**Particolari** | struttura dalla forma ottagonale realizzata artigianalmente.

Castel sospensione è dotato di doppia fonte luminosa led: luce diretta verso il basso e luce di atmosfera verso l'alto che ricrea un gioco di riflessi ottagonali. Le basi delle lampade sono in marmo sagomato.

Per qualsiasi richiesta o differente versione non esitate a contattarci.

**Finish** | satin gold, satin chrome, shiny chrome, RAL matt white. Other finishes on request.



**Marble Color** | marble bases in the variants: forest green, royal daino beige, marquinia black, spaider white, mystic brown, amazing grey.

**Details** | octagonal structure is produced handmade.

Castel suspension has a double led light source: the direct light downwards and the atmosphere light upwards.

The atmosphere light creates octagonal reflections. The lamp bases are in shaped marble material.

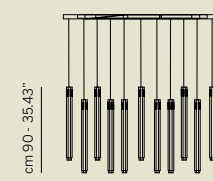
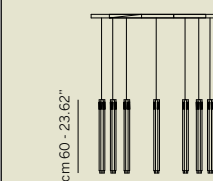
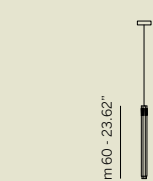
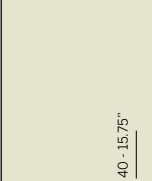
Don't hesitate to contact us for any request or different version.

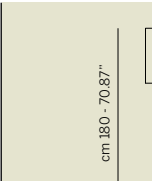
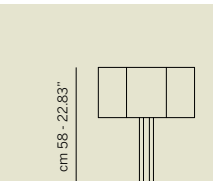
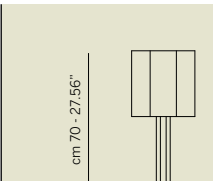
 <p>cm 90 - 35.43" cm 105 - 41.34"</p>	<p><b>CASTEL S16</b> 16 spot led 144W - 4000°K 220 Vdc - 11200 lm</p> <p>Aggancio altezza fissa (G) Hook with fixed height (G)</p> <p>metalli / metal</p>	 <p>cm 60 - 23.62" cm 70 - 27.56"</p>	<p><b>CASTEL S8</b> 8 spot led 72W - 4000°K 220 Vdc - 5600 lm</p> <p>Aggancio altezza fissa (G) Hook with fixed height (G)</p> <p>metalli / metal</p>
 <p>cm 60 - 23.62" cm 6 - 2.36"</p>	<p><b>CASTEL S1 G</b> 1 spot led 9W - 4000°K 220 Vdc - 700 lm</p> <p>Aggancio altezza fissa (G) Hook with fixed height (G)</p> <p>metalli / metal</p>	 <p>cm 40 - 15.75" cm 6 - 2.36"</p>	<p><b>CASTEL S1 SMALL</b> 1 spot led 9W - 4000°K 220 Vdc - 700 lm</p> <p>Aggancio altezza fissa (G) Hook with fixed height (G)</p> <p>metalli / metal</p>
 <p>cm 28 - 11.02" cm 6 x cm 9 - 2.36" x 3.54"</p>	<p><b>CASTEL WALL</b> 1 spot led 9W - 4000°K 220 Vdc - 700 lm</p> <p>metalli / metal</p>	 <p>cm 180 - 70.87" cm 40 - 15.75"</p>	<p><b>CASTEL PT</b> 1 bulb 7,5W - 4000°K 220 Vdc - 1000 lm</p> <p>marmo / marble</p> <p>metalli / metal</p>
 <p>cm 58 - 22.83" cm 40 - 15.75"</p>	<p><b>CASTEL LAMP</b> 1 bulb 7,5W - 4000°K 220 Vdc - 1000 lm</p> <p>marmo / marble</p> <p>metalli / metal</p>	 <p>cm 70 - 27.56" cm 21 - 8.27"</p>	<p><b>CASTEL TALL LAMP</b> 1 bulb 7,5W - 4000°K 220 Vdc - 1000 lm</p> <p>marmo / marble</p> <p>metalli / metal</p>

## CRYROCK

design by Michele Losito

**Finitura** | oro lucido. Altre finiture su richiesta.









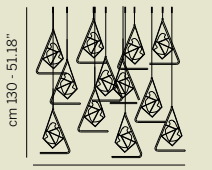

**Colori** | rosaline gleam, trasparente, topazio, viridian. Altri colori su richiesta.

**Particolari** | Cryrock è una collezione brevettata. Il sasso in cristallo è made in Toscana, viene lavorato al fine di eliminare gli spigoli e arrotondarne le forme. Non subisce alcun lavoro di molatura e ciò consente un risultato unico e non riproducibile in serie. La struttura in metallo è realizzata artigianalmente su nostro disegno con saldature in argento. Il filamento Led illumina ed esalta il cristallo. La sospensione S12 è un esempio: è possibile richiedere differenti configurazioni, forme e numero di elementi. Per qualsiasi richiesta o differente versione non esitate a contattarci.

**Finish** | shiny gold. Other finishes on request.

**Color** | rosaline gleam, transparent, topaz, viridian. Other colors on request.

**Details** | Cryrock is a patented collection. Crystal rock made in Tuscany. The rock is worked in order to smooth the edges off and to round its shape. It does not undergo any grinding work and this allows a unique result that can't be reproduced in series. The metal structure is handcrafted on our drawing with silver welds. The Led filament illuminates and highlights the crystal. The suspension S12 is an example: it's possible to request different configurations, shapes and number of elements. Don't hesitate to contact us for any request or different version.

 <p>cm 26 - 10.24"</p> <p>cm 17 x cm 15 - 6.69" x 5.91"</p>	<p><b>CRYROCK S1</b> 1 tinylight 2W - 3500°K - 24 Vdc 300 lm</p> <p><b>Aggancio con tirante (A). Hook with metal cable (A).</b></p> <p>vetri / glass </p> <p>metalli / metal </p>	 <p>cm 130 - 51.18"</p> <p>cm 130 x cm 50 - 51.18" x 19.69"</p>	<p><b>CRYROCK S12</b> 12 tinylight 24W - 3500°K - 24 Vdc 3600 lm</p> <p><b>Aggancio con tirante (A). Hook with metal cable (A).</b></p> <p>vetri / glass </p> <p>metalli / metal </p>
 <p>cm 26 - 10.24"</p> <p>cm 15 x cm 18 - 5.91" x 7.09"</p>	<p><b>CRYROCK WALL</b> 1 tinylight 2W - 3500°K - 24 Vdc 300 lm</p> <p>vetri / glass </p> <p>metalli / metal </p>	 <p>cm 28 - 11.02"</p> <p>cm 18 x cm 16 - 7.09" x 6.30"</p>	<p><b>CRYROCK LAMP</b> 1 tinylight 2W - 3500°K - 24 Vdc 300 lm</p> <p>vetri / glass </p> <p>metalli / metal </p>

## DUO





design by Studio in project

**Finitura** | doppia colorazione: nero opaco-oro champagne satinato / cedro-nero opaco / tortora-oro champagne satinato / verde petrolio-oro champagne satinato / rame-nero opaco. Altre finiture su richiesta.

**Particolari** | strutture in alluminio stampato. Tecnica doppia colorazione realizzata artigianalmente da maestri decoratori. Per qualsiasi richiesta o differente versione non esitate a contattarci.

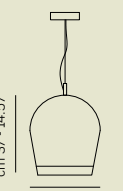
**Finish** | double decoration: opaque black-satin gold champagne / lime green-opaque black / dove gray-satin gold champagne / petrol green-satin gold champagne / copper color-opaque black. Other finishes on request.

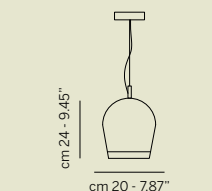
**Details** | the structure is made of cast aluminum. Duo is decorated handmade by master craftsmen with the double decorative technique. Don't hesitate to contact us for any request or different version.

 <p>cm 37 - 14.57"</p> <p>cm 30 - 11.81"</p>	<p><b>DUO S1 BIG</b> 1 bulb E27 10W - 4000°K 220 Vdc - 1000 lm</p> <p><b>Aggancio con tirante (A). Hook with metal cable (A).</b></p> <p>metalli / metal </p>	 <p>cm 24 - 9.45"</p> <p>cm 20 - 7.87"</p>	<p><b>DUO S1 SMALL</b> 1 bulb E14 7W - 4000°K 220 Vdc - 800 lm</p> <p><b>Aggancio con tirante (A). Hook with metal cable (A).</b></p> <p>metalli / metal </p>
---	--	--	--

## EFFECT

design by Michele Losito

**Finitura** | nichel nero. Altre finiture su richiesta.





**Colori** | tubi a stella e tubi pieni in vetro di murano nei colori acquamarina e ottanio oppure tabacco; tubi in borosilicato porta luci nel colore fumè satinato. Altri colori su richiesta.

**Particolari** | struttura in ferro realizzata artigianalmente. Boccole in ottone tornito. Effect è composto da tubi porta luce in borosilicato, tubi stella in borosilicato e tubi pieni in vetro di murano

**Finish** | black nickel . Other finishes on request.

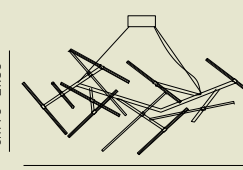
**Color** | tubes with stars section and full Murano glass tubes are in aquamarine and teal blue colors or in tobacco colors; borosilicate bulb holder tubes are in satin fumè color. Other colors on request.

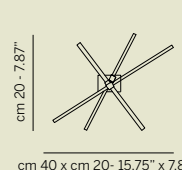
**Details** | the metal structure is produced handmade. Brass bushes. Effect has borosilicate bulb holder tubes, borosilicate tubes with stars section and full Murano glass tubes. Don't hesitate to contact us for any request or different version.

 <p>cm 70 - 27.56"</p> <p>cm 140 x cm 6 - 55.12" x 25.98"</p>	<p><b>EFFECT L14</b> 18 bulb G4 28W - 2700°K 12 Vdc - 2800 lm</p> <p><b>Aggancio con tiranti per sospensioni (C) Hook with metal cables for suspensions (C)</b></p> <p>vetri / glass </p> <p>metalli / metal </p>	 <p>cm 20 - 7.87"</p> <p>cm 40 x cm 20 - 15.75" x 7.87"</p>	<p><b>EFFECT A2</b> 2 bulb G4 4W - 2700°K 12 Vdc - 400 lm</p> <p>vetri / glass </p> <p>metalli / metal </p>
--	---	--	---

## GIRASOLE

design by Nunzia Acquaviva

**Finitura** | RAL oro champagne, marrone stagno opaco. Altre finiture su richiesta.

**Colori** | dischi in vetro nel colore trasparente satinato o marrone satinato. Altri colori su richiesta.







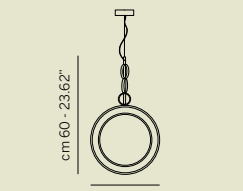

**Particolari** | strutture realizzate artigianalmente su nostro disegno. Dischi in vetro made in Veneto. Per qualsiasi richiesta o differente versione non esitate a contattarci.

**Finish** | RAL champagne gold color, opaque tin brown. Other finishes on request.

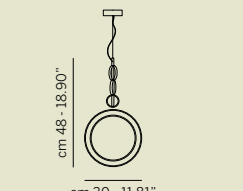
**Color** | disks in satin transparent color or satin brown color. Other colors on request.

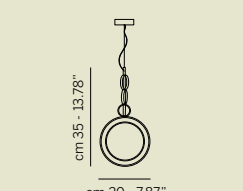
**Details** | metal structures are produced handmade on our drawing. Glass disks made in Venice.

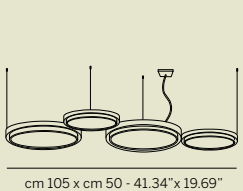
Don't hesitate to contact us for any request or different version.

 <p>cm 60 - 23.62"</p> <p>cm 40 - 15.75"</p>	<p><b>GIRASOLE 40</b> 1 stripled 22W - 4000°K 24 Vdc - 1781 lm</p> <p><b>Aggancio con tirante (A). Hook with metal cable (A).</b></p> <p>vetri / glass </p> <p>metalli / metal </p>	 <p>cm 48 - 18.90"</p> <p>cm 30 - 11.81"</p>	<p><b>GIRASOLE 30</b> 1 stripled 16W - 4000°K 24 Vdc - 1319 lm</p> <p><b>Aggancio con tirante (A). Hook with metal cable (A).</b></p> <p>vetri / glass </p> <p>metalli / metal </p>
 <p>cm 35 - 13.78"</p> <p>cm 20 - 7.87"</p>	<p><b>GIRASOLE 20</b> 1 stripled 9W - 4000°K 24 Vdc - 791 lm</p> <p><b>Aggancio con tirante (A). Hook with metal cable (A).</b></p> <p>vetri / glass </p> <p>metalli / metal </p>	 <p>cm 5 - 1.97"</p> <p>cm 105 x cm 50 - 41.34" x 19.69"</p>	<p><b>GIRASOLE HORIZONTAL</b> 1 stripled 56W - 4000°K 24 Vdc - 4682 lm</p> <p><b>Aggancio con tiranti e tasselli a soffitto (F). Hook with metal cables and ceiling cable gripper (F)</b></p> <p>vetri / glass </p> <p>metalli / metal </p>



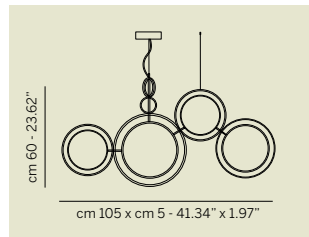

**GIRASOLE VERTICAL**  
1 stripled 56W - 4000°K  
24 Vdc - 4682 lm  
Aggancio con tiranti e tasselli a soffitto (F). Hook with metal cables and ceiling cable gripper (F)

vetri / glass  
metalli / metal

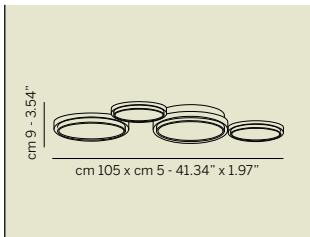

**GIRASOLE CEILING**  
1 stripled 56W - 4000°K  
24 Vdc - 4682 lm

vetri / glass  
metalli / metal

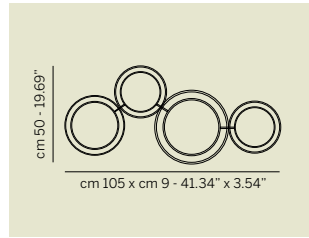

**GIRASOLE WALL**  
1 stripled 56W - 4000°K  
24 Vdc - 4682 lm

vetri / glass  
metalli / metal

## GLEAM

design by Studio in project

**Finitura** | nichel nero lucido, oro satinato. Altre finiture su richiesta.  
**Colori** | tubi cristallo nel colore rosoline gleam, acquamarina, verde diamond e trasparente. Altri colori su richiesta.  
**Particolari** | strutture realizzate artigianalmente su nostro disegno. Cristallo molato made in Toscana.  
Per qualsiasi richiesta o differente versione non esitate a contattarci.

**Finish** | black nickel, satin gold. Other finishes on request.  
**Color** | crystal elements in rosoline gleam color, aquamarine color, diamond green color and in transparent color.  
Other colors on request.  
**Details** | metal structures are produced handmade on our drawing. Polished crystal made in Tuscany.  
Don't hesitate to contact us for any request or different version.

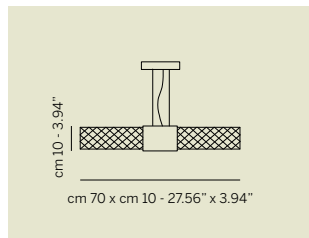

**GLEAM 2**  
2 spot led 9W - 4000°K  
220 Vdc - 700 lm  
Aggancio con tiranti per sospensioni (C). Hook with metal cables for suspensions (C)

vetri / glass  
metalli / metal

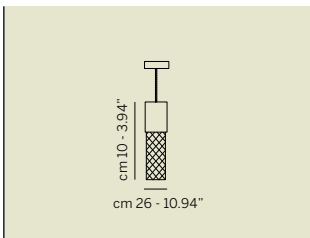

**GLEAM 1**  
1 spot led 4,5W - 4000°K  
220 Vdc - 350 lm  
Aggancio con cavo di alimentazione (D). Hook with power cord (D).

vetri / glass  
metalli / metal

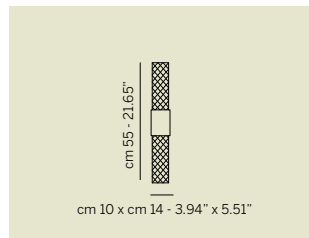

**GLEAM WALL**  
1 spot led 9W - 4000°K  
220 Vdc - 700 lm

vetri / glass  
metalli / metal

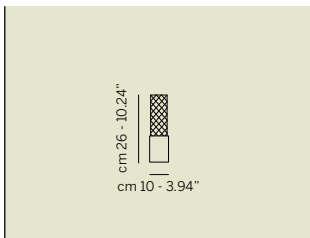

**GLEAM LAMP**  
1 spot led 4,5W - 4000°K  
220 Vdc - 350 lm

vetri / glass  
metalli / metal

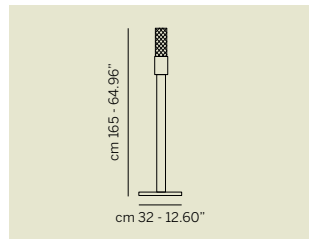

**GLEAM PT1**  
1 spot led 4,5W - 4000°K  
220 Vdc - 350 lm

vetri / glass  
metalli / metal

## MIKADO

design by Nunzia Acquaviva

**Finitura** | nichel nero, oro lucido. Altre finiture su richiesta.  
**Colori** | sfere pyrex nel colore nichel nero metallizzato o oro metallizzato. Altri colori su richiesta.  
**Particolari** | sfere in pyrex con decorazione metallizzata che consente di nascondere la fonte luminosa quando la sospensione è spenta. Accesa la sospensione mostra all'interno un filamento led.  
La sospensione S12 è un esempio: è possibile richiedere differenti configurazioni, forme e numero di elementi.  
Per qualsiasi richiesta o differente versione non esitate a contattarci.

**Finish** | black nickel, shiny gold. Other finishes on request.  
**Color** | pyrex spheres in metallic black nickel or in metallic shiny gold. Other colors on request.  
**Details** | pyrex spheres with metallic decoration: when the suspension is off the light source cannot be seen; when the suspension is on, the led filament can be seen. The suspension S12 is an example: it's possible to request different configurations, shapes and number of elements. Don't hesitate to contact us for any request or different version.

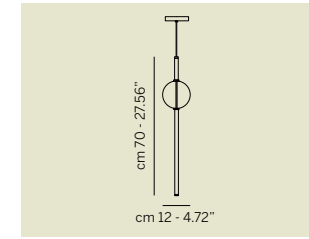

**MIKADO IN**  
1 tinylight 2W - 3500°K  
24 Vdc - 300 lm  
Aggancio con cavo di alimentazione (D). Hook with power cord (D).

vetri / glass  
metalli / metal

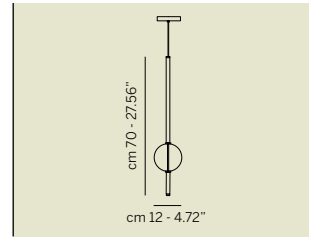

**MIKADO OUT**  
1 tinylight 2W - 3500°K  
24 Vdc - 300 lm  
Aggancio con cavo di alimentazione (D). Hook with power cord (D).

vetri / glass  
metalli / metal

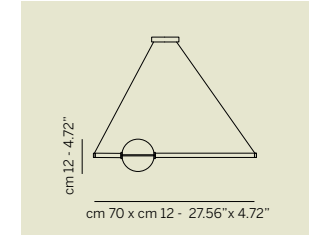

**MIKADO HORIZON**  
1 tinylight 2W - 3500°K  
24 Vdc - 300 lm  
Aggancio con tirante e cavo di alimentazione per sospensioni (E). Hook with metal cables and power cord for suspension (E).

vetri / glass  
metalli / metal

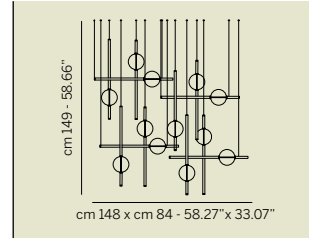

**MIKADO S12**  
12 tinylight 24W - 3500°K  
24 Vdc - 7200 lm  
Aggancio con cavo di alimentazione (D). Hook with power cord (D).  
Aggancio con tirante e cavo di alimentazione per sospensioni (E). Hook with metal cables and power cord for suspension (E).

vetri / glass  
metalli / metal

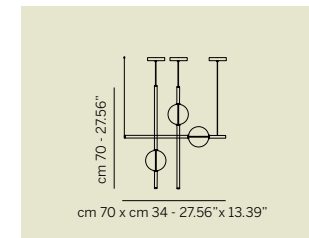

**MIKADO S3**  
3 tinylight 6W - 3500°K  
24 Vdc - 900 lm  
Aggancio con cavo di alimentazione (D). Hook with power cord (D).  
Aggancio con tirante e cavo di alimentazione per sospensioni (E). Hook with metal cables and power cord for suspension (E).

vetri / glass  
metalli / metal

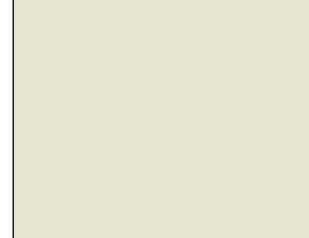

**MIKADO WALL**  
3 tinylight 6W - 3500°K  
24 Vdc - 900 lm

vetri / glass  
metalli / metal

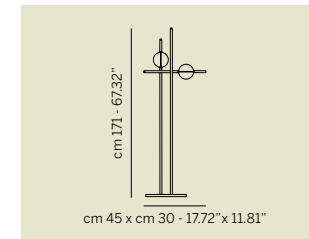

**MIKADO PT**  
2 tinylight 4W - 3500°K  
24 Vdc - 600 lm

vetri / glass  
metalli / metal











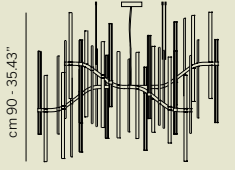

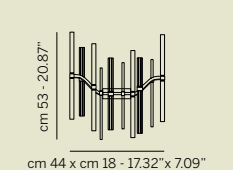

## NEVA

design by Daniel Becker

**Finitura** | oro satinato, cromo satinato. Altre finiture su richiesta.**Colori** | tubi a stella e tubi pieni in vetro di murano trasparenti; tubi in borosilicato porta luci nel colore opalino bianco. Altri colori su richiesta.**Particolari** | strutture in ferro realizzate artigianalmente. Boccole in ottone tornito.

Neva è composto da tubi porta luce in borosilicato, tubi stella in borosilicato e tubi pieni in vetro di murano. Per qualsiasi richiesta o differente versione non esitate a contattarci.





**Finish** | satin gold, satin chrome. Other finishes on request.**Color** | tubes with stars section and full Murano glass tubes are transparent; Borosilicate bulb holder tubes are in opaline white color. Other colors on request.**Details** | the metal structure is produced handmade. Brass bushes. Neva has borosilicate bulb holder tubes, borosilicate tubes with stars section and full Murano glass tubes. Don't hesitate to contact us for any request or different version.





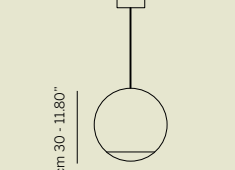

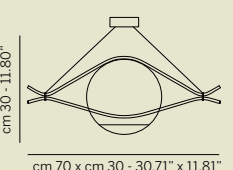
 <p>cm 90 - 35.43" cm 113 x cm 36 - 44.49" x 14.17"</p>	<p><b>NEVA 24</b> 24 G4 bulb 48W - 2700°K 12 Vdc - 4800 lm</p> <p>Aggancio con tiranti e tasselli a soffitto (F). Hook with metal cables and ceiling cable gripper (F)</p> <p>vetri / glass   metalli / metal  </p>	 <p>cm 53 - 20.87" cm 44 x cm 18 - 17.32" x 7.09"</p>	<p><b>NEVA A8</b> 8 G4 bulb 16W - 2700°K 12 Vdc - 1600 lm</p> <p>vetri / glass   metalli / metal  </p>
 <p>cm 53 - 20.87" cm 32 x cm 9 - 12.60" x 3.54"</p>	<p><b>NEVA A6</b> 6 G4 bulb 12 W - 2700°K 12 Vdc - 1200 lm</p> <p>vetri / glass   metalli / metal  </p>		

## NOBODY

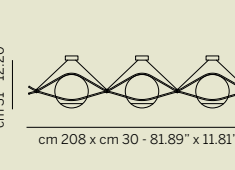
design by Alberto Ghirardello

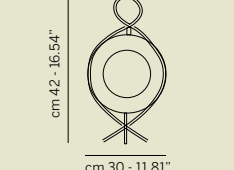
**Finitura** | nichel nero, oro lucido, RAL rosso bronzo. Altre finiture su richiesta.**Colori** | sfere nel colore opalino bianco. Altri colori su richiesta.**Particolari** | sfere in PMMA. Strutture in ferro realizzate artigianalmente. La sospensione S3 è un esempio: è possibile richiedere differente numero di elementi. Per qualsiasi richiesta o differente versione non esitate a contattarci.**Finish** | black nickel, shiny gold, RAL red bronze. Other finishes on request.**Color** | sphere in opaline white color. Other colors on request.**Details** | sphere in PMMA material. The iron structures are produced handmade. The suspension S3 is an example: it's possible to request different number of elements. Don't hesitate to contact us for any request or different version.

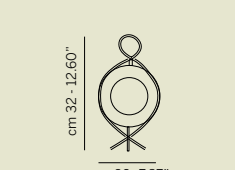









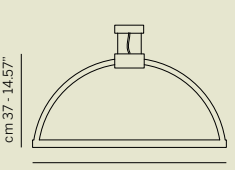



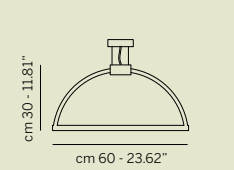

 <p>cm 30 - 11.80" cm 30 - 11.80"</p>	<p><b>NOBODY SPHERE</b> 1 E27 bulb 7,5W - 4000°K 220 Vdc - 1000 lm</p> <p>Aggancio con cavo di alimentazione (D). Hook with power cord (D).</p> <p>metalli / metal  </p>	 <p>cm 30 - 11.80" cm 70 x cm 30 - 30.71" x 11.81"</p>	<p><b>NOBODY S1</b> 1 E27 bulb 7,5W - 4000°K 220 Vdc - 1000 lm</p> <p>Aggancio con tiranti per sospensioni (C). Hook with metal cables for suspensions (C)</p> <p>metalli / metal  </p>
--	--	--	---

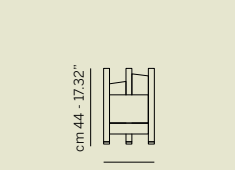
 <p>cm 31 - 12.20" cm 208 x cm 30 - 81.89" x 11.81"</p>	<p><b>NOBODY S3</b> 3 E27 bulb 22,5W - 4000°K 220 Vdc - 3000 lm</p> <p>Aggancio con tiranti per sospensioni (C). Hook with metal cables for suspensions (C)</p> <p>metalli / metal  </p>	 <p>cm 42 - 16.54" cm 30 - 11.81"</p>	<p><b>NOBODY BIG LAMP</b> 1 E27 bulb 7,5W - 4000°K 220 Vdc - 1000 lm</p> <p>metalli / metal  </p>
 <p>cm 32 - 12.60" cm 20 - 7.87"</p>	<p><b>NOBODY SMALL LAMP</b> 1 E27 bulb 7,5W - 4000°K 220 Vdc - 1000 lm</p> <p>metalli / metal  </p>		

## PATCHWORK

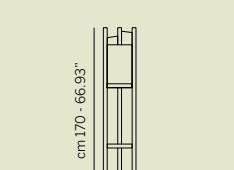
design by Sovrappensiero

**Finitura** | RAL nero opaco, RAL bronze. Altre finiture su richiesta.**Colori** | trasparente satinato o marrone. Altri colori su richiesta.**Particolari** | strutture in ferro realizzate artigianalmente. Vetri cattedrale sagomati made in Veneto. Per qualsiasi richiesta o differente versione non esitate a contattarci.**Finish** | RAL matt black, RAL bronze. Other finishes on request.**Color** | Satin transparent color, brown color. Other colors on request.**Details** | metal structures are produced handmade. Shaped cathedral glass made in Venice. Don't hesitate to contact us for any request or different version.

 <p>cm 37 - 14.57" cm 90 - 35.43"</p>	<p><b>PATCHWORK 90</b> 1 wide flood 18W - 4000°K 220 Vdc - 1800 lm</p> <p>Aggancio con tiranti per sospensioni (C). Hook with metal cables for suspensions (C)</p> <p>vetri / glass   metalli / metal  </p>	 <p>cm 30 - 11.81" cm 60 - 23.62"</p>	<p><b>PATCHWORK 60</b> 1 wide flood 12W - 4000°K 220 Vdc - 850 lm</p> <p>Aggancio con tiranti per sospensioni (C). Hook with metal cables for suspensions (C)</p> <p>vetri / glass   metalli / metal  </p>
 <p>cm 44 - 17.32" cm 25 - 9.84"</p>	<p><b>PATCHWORK LAMP</b> 1 spot led 4,5W - 4000°K 220 Vdc - 350 lm</p> <p>vetri / glass   metalli / metal  </p>	 <p>cm 170 - 66.93" cm 30 - 11.81"</p>	<p><b>PATCHWORK PT</b> 1 wide flood 12W - 4000°K 220 Vdc - 850 lm</p> <p>vetri / glass   metalli / metal  </p>

## PROFILE

design by Studio in project

**Finitura** | RAL nero opaco, oro. Altre finiture su richiesta.

**Particolari** | strutture in alluminio realizzate artigianalmente. È possibile richiedere Profile monoluce con luce direzionata verso il basso o biluce con luce direzionata verso l'alto e verso il basso. Per qualsiasi richiesta o differente versione non esitate a contattarci.

**Finish** | RAL matt black, gold. Other finishes on request.

**Details** | aluminum structures are produced handmade. It is possible to request Profile with one light downward or with two lights downward and upward. Don't hesitate to contact us for any request or different version.

	<p><b>PROFILE PROJECT 120</b> 3 striped snk 30W - 3000°K 24 Vdc - 3631 lm</p> <p>Aggancio con tiranti per sospensioni (C) Hook with metal cables for suspensions (C)</p> <p>metalli / metal</p>		<p><b>PROFILE 120</b> 1 striped snk 15W - 3000°K 24 Vdc - 1824 lm</p> <p>Aggancio con tiranti per sospensioni (C) Hook with metal cables for suspensions (C)</p> <p>metalli / metal</p>
	<p><b>PROFILE 80</b> 1 striped snk 10W - 3000°K 24 Vdc - 1205 lm</p> <p>Aggancio con tiranti per sospensioni (C) Hook with metal cables for suspensions (C)</p> <p>metalli / metal</p>		<p><b>PROFILE 40</b> 1 striped snk 5W - 3000°K 24 Vdc - 602 lm</p> <p>Aggancio con tiranti per sospensioni (C) Hook with metal cables for suspensions (C)</p> <p>metalli / metal</p>
	<p><b>PROFILE OVAL 180X40</b> 1 striped snk 19,2W - 4000°K 24 Vdc - 2328 lm</p> <p>Aggancio con tiranti e tasselli a soffitto (F). Hook with metal cables and ceiling cable gripper (F)</p> <p>metalli / metal</p>		<p><b>PROFILE OVAL 160X40</b> 1 striped snk 17W - 4000°K 24 Vdc - 1992 lm</p> <p>Aggancio con tiranti e tasselli a soffitto (F). Hook with metal cables and ceiling cable gripper (F)</p> <p>metalli / metal</p>
	<p><b>PROFILE OVAL 140X40</b> 1 striped snk 13,6W - 4000°K 24 Vdc - 1632 lm</p> <p>Aggancio con tiranti e tasselli a soffitto (F). Hook with metal cables and ceiling cable gripper (F)</p> <p>metalli / metal</p>		

## QUADRO

design by Michele Losito

**Finitura** | RAL oro champagne, Ral nero opaco. Altre finiture su richiesta.

**Colori** | nella versione glass, il vetro sagomato effetto cattedrale è possibile nel colore trasparente satinato, ambrà, fumè. Altri colori su richiesta.

**Particolari** | differenti versioni consentono di personalizzare quadro: **versione fabric** è composta da telai rivestiti artigianalmente con tecnica dei paralumi; **versione glass** prevede l'inserimento di lastre vetro sagomato effetto cattedrale; **versione glass&fabric**: affianca telai rivestiti in tessuto con lastre in vetro cattedrale.

È possibile scegliere la collezione Quadro nelle configurazioni proposte o personalizzarla totalmente sostituendo tessuti e vetri. I telai e i vetri sono removibili consentendone la sostituzione in qualsiasi momento. Per qualsiasi richiesta o differente versione non esitate a contattarci.

**Finish** | Ral champagne gold, Ral opaque black. Other finishes on request.

**Color** | In the glass version, it is possible to request the shaped cathedral glass in the satin transparent color or in amber color or in fumè color. Other colors on request.

**Details** | it is possible to personalized the collection with different versions: **Fabric version** with coated frames produced handmade with lampshades technique. **Glass version** with shaped cathedral glass. **Glass&fabric version** with both coated frames and glasses. It is possible to request the Quadro collection as in the suggested configurations or to request a total customization with other textures and glasses. The frames and the glasses are removable in order to change the appearance at all times. Don't hesitate to contact us for any request or different version.

	<p><b>QUADRO WALL</b> 4 striped 88W - 4000°K 24 Vdc - 8800 lm</p> <p>vetri / glass</p> <p>metalli / metal</p>		<p><b>QUADRO WALL A</b> 1 striped 24W - 4000°K 24 Vdc - 2400 lm</p> <p>vetri / glass</p> <p>metalli / metal</p>
	<p><b>QUADRO WALL B</b> 1 striped 20W - 4000°K 24 Vdc - 2000 lm</p> <p>vetri / glass</p> <p>metalli / metal</p>		<p><b>QUADRO WALL C</b> 1 striped 20W - 4000°K 24 Vdc - 2000 lm</p> <p>vetri / glass</p> <p>metalli / metal</p>
	<p><b>QUADRO WALL D</b> 1 striped 20W - 4000°K 24 Vdc - 2000 lm</p> <p>vetri / glass</p> <p>metalli / metal</p>		

## RAINBOW

design by Studio in project

**Finitura** | nichel nero, oro satinato. Altre finiture su richiesta.





**Colori** | esterno oro effetto tela, con interno azzurro; esterno effetto tela fumè, con interno fumè; esterno effetto tela blu, con interno blu; esterno effetto tela acquamarina, con interno azzurro; esterno effetto tela marrone, con interno marrone. Altri colori su richiesta.

**Particolari** | bocce di vetro made in Toscana. Particolare decorazione esterna effetto tela percepibile al tatto. Per qualsiasi richiesta o differente versione non esitate a contattarci.

**Finish** | black nickel, satin gold. Other finishes on request.

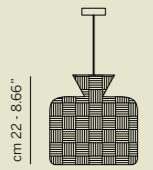
**Color** | exterior with gold canvas effect, with light blue interior; exterior with smoked canvas effect, with smoked interior; exterior with blue canvas effect, with blue interior; exterior with aquamarine canvas effect, with light blue interior; exterior with brown canvas effect, with brown interior. Other colors on request.

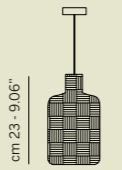
**Details** | glass bowls made in Tuscany. Particular external decoration with canvas effect perceptible to the touch. Don't hesitate to contact us for any request or different version.

 <p>cm 22 - 8.66" cm 24 - 9.45"</p>	<p><b>RAINBOW 24</b> 1 bulb E27 8W - 2200°K 220 Vdc - 300 lm</p> <p><b>Aggancio con cavo di alimentazione (D). Hook with power cord (D).</b></p> <p>vetri / glass  metalli / metal </p>	 <p>cm 23 - 9.06" cm 16 - 6.30"</p>	<p><b>RAINBOW 16</b> 1 bulb E27 8W - 2200°K 220 Vdc - 300 lm</p> <p><b>Aggancio con cavo di alimentazione (D). Hook with power cord (D).</b></p> <p>vetri / glass  metalli / metal </p>
--	---	--	---

## RHYTHM

design by Michele Losito

**Finitura** | oro satinato, marrone stagno finitura opaca. Altre finiture su richiesta.









**Colori** | sfere pyrex nel colore marrone satinato. Altri colori su richiesta.

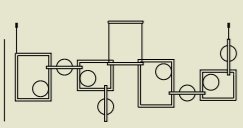

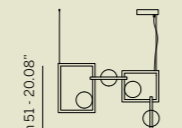

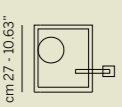
**Particolari** | sfere in pyrex con decorazione satinata. Strutture in metallo realizzate artigianalmente. La sospensione S8 è un esempio che indica la modularità: moltiplicando il modulo base S4 è possibile ottenere lunghezze e numero di luci differenti. Per qualsiasi richiesta o differente versione non esitate a contattarci.

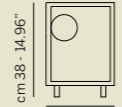
**Finish** | satin gold, opaque brown tin. Other finishes on request.

**Color** | pyrex spheres in satin brown color. Other colors on request.

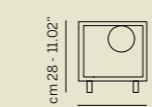
**Details** | pyrex spheres with satin decoration. The metal structure is produced handmade. The suspension S8 is an example to indicate the modularity: by multiplying the base module S4 it's possible to obtain different lengths and different number of lights. Don't hesitate to contact us for any request or different version.

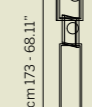
 <p>cm 64 - 25.20" cm 168 x cm 23 - 66.14" x 9.06"</p>	<p><b>RHYTHM 8</b> 8 G9 24W - 3000°K 220 Vdc - 2240 lm</p> <p><b>Aggancio con tiranti e tasselli a soffitto (F). Hook with metal cables and ceiling cable gripper (F)</b></p> <p>vetri / glass  metalli / metal </p>	 <p>cm 51 - 20.08" cm 74 x cm 23 - 29.13" x 9.06"</p>	<p><b>RHYTHM 4</b> 4 G9 12W - 3000°K 220 Vdc - 1120 lm</p> <p><b>Aggancio con tiranti e tasselli a soffitto (F). Hook with metal cables and ceiling cable gripper (F)</b></p> <p>vetri / glass  metalli / metal </p>
 <p>cm 27 - 10.63" cm 30 x cm 16 - 11.81" x 6.30"</p>	<p><b>RHYTHM WALL</b> 1 G9 3W - 3000°K 220 Vdc - 280 lm</p> <p>vetri / glass  metalli / metal </p>	 <p>cm 38 - 14.96" cm 23 x cm 12 - 9.06" x 4.72"</p>	<p><b>RHYTHM BIG LAMP</b> 1 G9 3W - 3000°K 220 Vdc - 280 lm</p> <p>vetri / glass  metalli / metal </p>

 <p>cm 28 - 11.02" cm 27 x cm 12 (w) - 10.63" x 4.72"</p>	<p><b>RHYTHM SMALL LAMP</b> 1 G9 3W - 3000°K 220 Vdc - 280 lm</p> <p>vetri / glass  metalli / metal </p>	 <p>cm 17.3 - 6.811" cm 23 x cm 27 (w) - 9.06" x 10.63"</p>	<p><b>RHYTHM PT</b> 2 G9 6W - 3000°K 220 Vdc - 560 lm</p> <p>vetri / glass  metalli / metal </p>
--	--	--	--

## SOUND

design by Michele Losito

**Finitura** | Ral colore bordeaux-argento, RAL nero opaco-argento. Altre finiture su richiesta.







**Colori** | vetro trasparente. Altri colori su richiesta.

**Particolari** | strutture realizzate artigianalmente su nostro disegno, ispirato a microfoni anni '70. Vetro effetto puntini made in Veneto. Per qualsiasi richiesta o differente versione non esitate a contattarci.

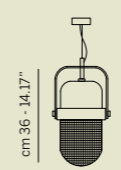
**Finish** | RAL bordeaux-silver color, RAL matte black-silver color. Other finishes on request.

**Color** | transparent glass. Other colors on request.

**Details** | metal structures are produced handmade on our drawing, inspired by 70's microphones. Don't hesitate to contact us for any request or different version.

 <p>cm 36 - 14.17" cm 14 - 5.51"</p>	<p><b>SOUND S1</b> 1 spot led 3W - 4000°K 12 Vdc - 310 lm</p> <p><b>Aggancio con tirante (A). Hook with metal cable (A).</b></p> <p>vetri / glass  metalli / metal </p>	 <p>cm 38 - 14.96" cm 14 - 5.51"</p>	<p><b>SOUND LAMP</b> 1 spot led 3W - 4000°K 12 Vdc - 310 lm</p> <p>vetri / glass  metalli / metal </p>
--	---	--	--

## VECTOR

design by Nunzia Acquaviva

**Finitura** | oro lucido-oro satinato / nichel nero lucido-nichel nero opaco. Altre finiture su richiesta.

**Colori** | dischi nel colore fumè grigio e nel colore bronzo. Altri colori su richiesta.

**Particolari** | strutture realizzate artigianalmente su nostro disegno.





Per qualsiasi richiesta o differente versione non esitate a contattarci.

**Finish** | shiny gold-satin gold / black nickel-matt black nickel. Other finishes on request.

**Color** | disks in smoky grey color and in bronze color. Other colors on request.

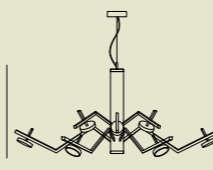
**Details** | metal structures are produced handmade on our drawing.

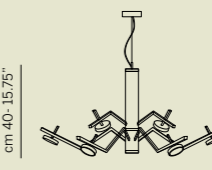
Don't hesitate to contact us for any request or different version.

 <p>cm 42 - 16.54" cm 115 - 45.28"</p>	<p><b>VECTOR L6+6</b> 12 strip led 72W - 4000°K 24 Vdc - 6336 lm</p> <p><b>Aggancio con tirante (A). Hook with metal cable (A).</b></p> <p>vetri / glass  metalli / metal </p>	 <p>cm 40 - 15.75" cm 93 - 36.61"</p>	<p><b>VECTOR L4+4</b> 8 strip led 48W - 4000°K 24 Vdc - 4224 lm</p> <p><b>Aggancio con tirante (A). Hook with metal cable (A).</b></p> <p>vetri / glass  marmo / marble </p>
---	--	--	--

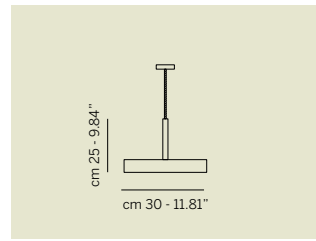

**VECTOR 30**  
 1 strip led 40W - 4000°K  
 24 Vdc - 3360 lm  
**Aggancio con cavo di alimentazione (D).**  
**Hook with power cord (D).**

vetri / glass   
 metalli / metal 

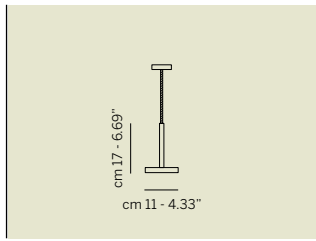

**VECTOR 10**  
 1 strip led 6W - 4000°K  
 24 Vdc - 528 lm  
**Aggancio con cavo di alimentazione (D).**  
**Hook with power cord (D).**

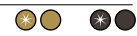
vetri / glass   
 marmo / marble 

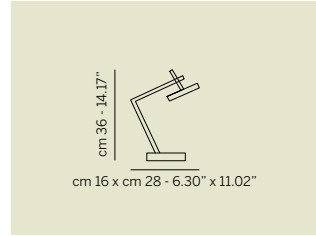

**VECTOR LAMP**  
 1 strip led 6W - 4000°K  
 24 Vdc - 528 lm

vetri / glass   
 metalli / metal 

**FINISHES**

## GLASS FINISHES



Trasparente  
*Transparent*



Bianco opalino  
*Opaline white*



Fumè grigio  
*Fumè grey*



Verde diamond  
*Diamond green*



Rosaline gleam

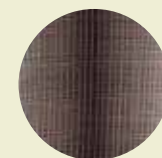

Fumè effetto tela  
*Fumè canvas effect*



Blu effetto tela  
*Blu canvas effect*

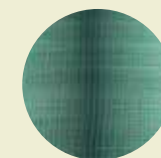

Acquamarina effetto tela  
*Aquamarine canvas effect*



Marrone effetto tela  
*Brown canvas effect*



Acquamarina  
*Aquamarine*



Ambra  
*amber*



Topazio  
*Topaz*



Viridian



Tabacco  
*Tobacco*



Ottanio  
*Teal blue*



Trasparente satinato  
*Satin transparent*



Marrone satinato  
*Satin brown*



Fumè satinato  
*Satin fumè*



Acquamarina satinato  
*Satin aquamarine*

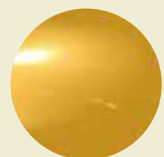

Ambra satinato  
*Satin amber*



Verde diamond satinato  
*Satin green diamond*



Nichel nero metallizzato  
*Metallic black nichel*



Oro lucido metallizzato  
*Metallic shiny gold*



Oro effetto tela  
*Gold canvas effect*

## METAL FINISHES



Cromo lucido  
*Shiny chrome*

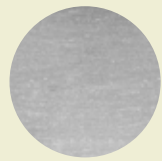

Cromo satinato  
*Satin chrome*



Oro 24k lucido  
*Shiny gold 24k*



Oro 24k satinato  
*Satin gold 24k*



Marrone stagno opaco  
*Matt tin brown*



Nichel nero  
*Black nichel*



RAL bronzo  
*Ral bronze*



RAL bronzo rosso  
*RAL red bronze*

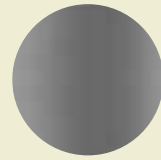

RAL argento  
*RAL silver*

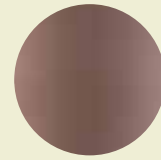

RAL rame  
*RAL copper*



RAL cedro  
*RAL lime green*



RAL verde petrolio  
*RAL green petrol*



RAL nero opaco  
*RAL opaque black*



RAL champagne gold



RAL 9005 - black

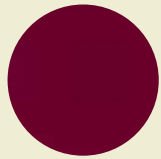

RAL 4004 - bordeaux



RAL tortora - dove gray

## MARBLE FINISHES



Amazing grey

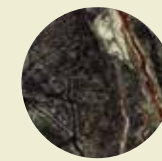

Forest green



Marquina black



Mystick brown



Royal Daino beige



Spider white



**H O O K S**

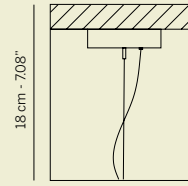

**AGGANCIO CON TIRANTE (A) - HOOK WITH METAL CABLE (A)**

L'altezza dei lampadari è calcolata escludendo l'aggancio.  
 Aggancio con rosone e filo tirante H minima 18 cm - 7.08".

The height of the chandeliers is calculated by excluding the hook.  
 Hook with the ceiling cup and cable has the minimum height 18 cm - 7.08".

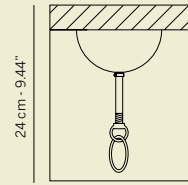

**AGGANCIO CON CATENA (B) - HOOK WITH CHAIN (B)**

L'altezza dei lampadari è calcolata escludendo l'aggancio.  
 Aggancio con rosone e catena H minima 24 cm - 9.44".

The height of the chandeliers is calculated by excluding the hook.  
 Hook with the ceiling cup and chain has the minimum height 24 cm - 9.44".

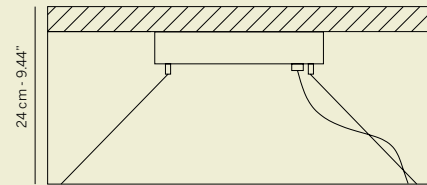

**AGGANCIO CON TIRANTI PER SOSPENSIONI (C)  
 HOOK WITH METAL CABLES FOR SUSPENSION (C)**

L'altezza delle sospensioni è calcolata escludendo l'aggancio.  
 Aggancio con rosone e tiranti H minima 24 cm - 9.44"

The height of suspensions is calculated by excluding the hook.  
 Hook with the ceiling cup and metal cables has the minimum height 24 cm - 9.44".

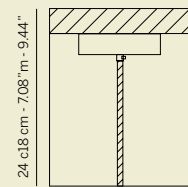

**AGGANCIO CON CAVO DI ALIMENTAZIONE (D)  
 HOOK WITH POWER CORD (D)**

L'altezza dei lampadari è calcolata escludendo l'aggancio.  
 Aggancio con rosone e cavo di alimentazione H minima 18 cm - 7.08".

The height of the chandeliers is calculated by excluding the hook.  
 Hook with the ceiling cup and power cord has the minimum height 18 cm - 7.08".

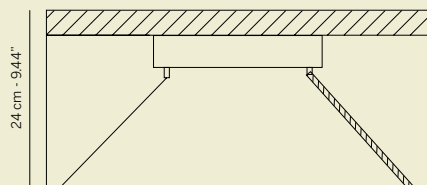

**AGGANCIO CON TIRANTE E CAVO DI ALIMETAZIONE  
 PER SOSPENSIONI (E)  
 HOOK WITH METAL CABLE AND POWER CORD  
 FOR SUSPENSION (E)**

L'altezza delle sospensioni è calcolata escludendo l'aggancio.  
 Aggancio con rosone, tirante e cavo di alimentazione H minima 24 cm - 9.44".

The height of suspensions is calculated by excluding the hook.  
 Hook with the ceiling cup, metal cable and power cord has the minimum height 24 cm - 9.44".

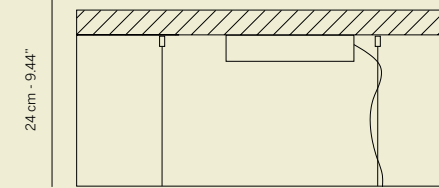

**AGGANCIO CON TIRANTI E TASSELLI A SOFFITTO (F)  
 HOOK WITH METAL CABLES AND CEILING CABLE GRIPPER (F)**

L'altezza delle sospensioni è calcolata escludendo l'aggancio.  
 Aggancio con rosone e tiranti con tasselli a soffitto H minima 24 cm - 9.44".

The height of suspensions is calculated by excluding the hook.  
 Hook with the ceiling cup and metal cables with ceiling cable gripper has the minimum height 24 cm. - 9.44".

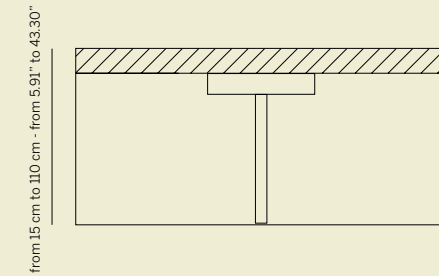

**AGGANCIO ALTEZZA FISSA (G) - HOOK WITH FIXED HEIGHT (G)**

L'altezza delle sospensioni è calcolata escludendo l'aggancio.  
 Aggancio con rosone e aste cilindriche fisse ha H minima 15 cm - 5.91" e H massima 110 cm - 43.30".

The height of the suspension is calculated excluding the hook.  
 Hook with ceiling cup and cylindrical rods has the minimum height 15 cm - 5.91" and the maximum height 110 cm - 43.30".









[www.twentybrandesign.it](http://www.twentybrandesign.it)  
t +39 0883 559385  
[info@twentybrandesign.it](mailto:info@twentybrandesign.it)  
[export@eurolucelampadari.it](mailto:export@eurolucelampadari.it)

—  
Txxnty Brand Design  
is registered trademarks  
of Euroluce\_light of Italy

—  
Graphic design: [www.artefattiadp.it](http://www.artefattiadp.it)  
Photography: Francesco Stragapede  
Post production: Leonardo Schifino  
Thanks to: LAS Mobili srl - las.it

—  
March 2020

